



Oil Water Separators

INSTALLATION, OPERATION & MAINTENANCE

1800 018 999
ALINEPUMPS.COM.AU

KWIKFLO
PUMP STATIONS & TRADE WASTE



Since commencing operation in 1995, Aline Pumps has been focused on providing pumping solutions to the residential and commercial market.

Our involvement includes designing, engineering and customising equipment to the exact requirements for property developments, industrial estates, commercial properties, hospital infrastructure, and mining projects. As reputation, experience and clientele grew, Aline established themselves as leading suppliers within the industry.

WHO WE ARE

Our people are the lifeblood of our company and are therefore vital to everything we do. We are dedicated to building quality, cost-effective Fire Protection Pumps, Pressure Systems, Trade Waste treatment equipment and Submersible Pump Systems. With a skilled, qualified, trained and committed team, Aline is currently servicing over fifteen hundred Sydney properties, in addition to multiple contracts with Australian Government, non-government and reputable strata organisations such as Bunnings, Sydney Opera House and Sydney's City Westfield.

OUR MISSION

"Aline is a close team that provides cost effectively engineered pump systems with quick turnaround and responsive service, ensuring customer confidence and peace of mind."

OUR VISION

"Aline's vision is to become the market leader in engineered pumping systems for the plumbing and fire industry. We will do this by becoming the brand of choice for consultants through continuous improvement, adaption to market needs and maintaining the highest level of industry expectation."

Our desire to not only meet but exceed all client and employee expectations is embedded within our values. Over the years, we have grown into a highly skilled team with improved facilities, establishing Aline as one of Australia's largest and most reliable pump suppliers.

CORE VALUES

In such a dynamic and evolving industry, innovation and accountability are vital to the success of our projects. We strive to "go the extra mile" in all client relationships, ensuring our fundamental core values of integrity, loyalty and transparency are met.

DISTRIBUTED BY:	INSTALLATION DATE:
	SERIAL NUMBER:

Contents

CONTENTS.....	3
PRODUCT INTRODUCTION.....	4
INSTALLATION	5
FREE-STANDING KWIKFLO KCPS COALESCING PLATE SEPARATOR.....	5
WALL-MOUNTED KWIKFLO KCPS-1000 COALESCING PLATE SEPARATOR.....	5
PROTECTION AGAINST DAMAGE AND VANDALISM	6
SILT ARRESTORS	6
SILT ARRESTORS	6
PIPEWORK	7
ADDITIONAL INSTRUCTIONS	8
INSTALLATION OF LEVEL FLOATS	8
OIL SKIMMERS.....	8
STARTING UP & COMMISSIONING	8
KWIKFLO DIAPHRAGM PUMPS & PIPEWORK	9
KWIKFLO DIAPHRAGM PUMPS & PIPEWORK	9
GEARBOX.....	10
TYPICAL ARRANGEMENT - STANDARD INSTALLATION	11
INSTALLATION DRAWINGS	12
GENERAL ARRANGEMENT - EXPLOSION PROOF INSTALLATION W/ CONTROL PANEL.....	12
TYPICAL ARRANGEMENT - WHEN PUMPING TO SEWER.....	13
FLOAT INSTALLATION IN COLLECTION PIT	14
TYPICAL ARRANGEMENT - SEWER CONNECTION.....	15
TRADE WASTE SAMPLING POINT	16
ELECTRICAL CONNECTIONS.....	17
ELECTRICAL CONNECTIONS.....	18
TECHNICAL DATA.....	19
KWIKFLO DIAPHRAGM PUMPS - DATASHEET	19
KDS DIAPHRAGM PUMP SPECIFICATION.....	19
DIMENSIONS & SPECIFICATION.....	20
KDS DIAPHRAGM PUMP DIMENSIONS	20
TECHNICAL DRAWINGS.....	21
KCPS-1000 FREE STANDING.....	21
KCPS-1000 WALL MOUNT.....	22
KCPS-1500 FREE STANDING.....	23
KCPS-2000 & KCPS-3000 FREE STANDING	24
PARTS LIST.....	26
SERVICE KITS.....	26
MAINTENANCE.....	27
DAILY MAINTENANCE.....	27
WEEKLY MAINTENANCE	27
THREE-MONTHLY MAINTENANCE.....	27
CLEANING FREQUENCY	28
MAINTENANCE OF THE DIAPHRAGM PUMP	28
REPLACEMENT OF FLAP VALVES.....	29
WARRANTY.....	30

Product Introduction

The unit covered in this manual is the Kwikflo KCPS Coalescing Plate Oil-Water-Solids Separator. The Kwikflo Coalescing Plate Separator is suitable for both free-standing and wall-mounted installations.

The Kwikflo KCPS Coalescing Plate Separator is a highly efficient device used for the removal of grease, oil and solid matter that is found in the waste water run-off from vehicle workshops, service stations, tank farms and washbays. The Kwikflo KCPS Coalescing Plate Separator is totally Australian made and the business is Australian owned.

Kwikflo KCPS Coalescing Plate Separators are designed with vertically arranged coalescing plates. From the inlet port, flow is directed through the vertically oriented plates where solids are separated under gravity for collection in the hopper below. Oil slugs rise immediately to the surface downstream a baffle or oil dam prevents the collected oil from entering the outlet weir.

The method of operation of the Kwikflo KCPS unit consists of four functions:

1. Oily water influent is pumped into the inlet chamber of the separator. Heavy solids settle and oil slugs rise to the surface.
2. The remaining oily water mixture flows through a stack of closely spaced Corrugated polypropylene plates.
3. Oil is automatically removed by an oil skimmer and collected in the oil drum.
4. Solids which have separated by gravity are collected below the plates in a sludge hopper, which incorporates a 50 mm drain valve specially designed for sludge removal.

All of these actions reduce the ingress of suspended solids of oil, grease and sludge into the sewer. There are no moving parts within the separator and the plate packs are easily removed for cleaning and replacement if necessary.

The compact nature of the unit makes it ideal for retrofitting into older premises and allows the customer to relocate the unit at a minimal expense. This factor is beneficial to the client/tenant as the costs are low, resulting in minimal capital investment to someone else's property.

Installation

FREE-STANDING KWIKFLO KCPS COALESCING PLATE SEPARATOR

When the Kwikflo KCPS Coalescing Plate Separator is installed as a free standing unit it must be placed in the Kwikflo galvanised frame provided with the unit and should be situated so that it does not obstruct access or emergency egress, cannot be damaged by vehicle traffic or potential vandalism and so that easy access is possible for maintenance. The proposed site should be level, minimum 100 mm thickness to enable it to Support the weight of the Kwikflo separator. The separator should be fastened to the plinth or slab by means of 10 mm Dynabolts, one bolt per leg in the pre-drilled holes provided. Packing under one or more of the legs may be necessary for the final levelling of the unit.

It is extremely important that the separator be mounted level to horizontal within tolerance of ± 2.5 mm to facilitate successful operation. All pipework leading to and from the Kwikflo separator shall be fully supported. Any stormwater shall be diverted away from the Kwikflo separator so as not to Undermine the concrete works. The Kwikflo Separator must not be used as a surcharge point. An additional gully must be installed downstream, after and at a lower level than the trap.

WALL-MOUNTED KWIKFLO KCPS-1000 COALESCING PLATE SEPARATOR

When the Kwikflo KCPS-1000 Coalescing plate Separator is installed as a wall Mounted unit it must be placed in the Kwikflo galvanised frame provided with the unit for that purpose. It must be situated so that it does not obstruct vehicular or emergency access. The lid opening should be 1500 mm from ground or floor. If installed above this height it should be fitted with access platform and stairs according to Australian Standards AS1657-1992 Sections 3 and 4. The proposed wall must be structurally sound with a minimum loading of 200 kg. It must be fastened by means of three 10 mm Dynabolts per side of the frame in the pre-drilled holes provided. It is extremely important that the separator be mounted level to the horizontal within tolerance of ± 2.5 mm to facilitate successful operation.

There must be a minimum space of 800 mm above the separator for removal of lid and for lifting out plate packs for cleaning. All pipework leading to and from the Kwikflo separator shall be fully supported.

Installation

PROTECTION AGAINST DAMAGE AND VANDALISM

In the case of either the free-standing or wall mounted Kwikflo separator being installed in a trafficable area, suitable protection bollards should be mounted accordingly. If there is a chance of damage by vandalism, it is recommended that a fence or cage be installed around the unit.

SILT ARRESTORS

While Kwikflo Separators can accommodate a nominal amount of sludge, when heavy solids, cloth or excessive silt is expected, provision should be made for accommodating them in the sump (minimum 500 litre working volume). The most economical method of achieving this is by a basket silt arrestor. It is advised that every installation incorporate a silt arrestor to minimise damage to the pump and separator.

SILT ARRESTORS

All installations are required to be carried out by a licensed plumber/drainer. The Kwikflo KCPS-1000 Coalescing Plate Separator should be located so as not to interfere with any statutory egress requirements, be in a position where damage by traffic is limited, not reduce access for emergency requirements or be exposed to possible vandalism. Approval from regulatory authorities must be gained before installation of the unit commences. The unit would also be installed in a position whereby it complies with the relevant safety codes of the applicable statutory authority. There are two different possible installation methods, as follows:

1. Pumped inlet and gravity outlet
2. Pumped inlet and pumped outlet

Either of the above combinations can be installed as free-standing (in galvanised frame) or wall-mounted (galvanised bracket). Kwikflo separator units should be mounted on a level, reinforced concrete plinth/slab of adequate thickness to take the weight of the unit. Refer page 6 under "Installation of Free Standing Separator". In the case of a wall mounted unit a structurally sound wall should be selected. Refer to "Installation of wall mounted separator".

Installation

PIPEWORK

- A. The suction and discharge pipe must always be equal to or larger than the inlet and outlet connections of the pump. Refer to table on page 10.
- B. Suction line from pit to pump must always be as direct as possible with a minimum number of bends. For further details on the suction line refer to the diaphragm pump section of this manual.
- C. The suction line should not touch the bottom of the pit. A gap of 100 mm should always be provided so as to safeguard against sludge or other sedimentation entering into the pipeline, causing damage to pump and blockages in line. Cleaning of this pit should be carried out regularly as discussed in the maintenance section.
- D. The suction line from the pit to the pump and from the pump to the separator must be free of all air leaks.
- E. Suction and discharge pipework should be adequately supported by stand off brackets or saddles at regular intervals to provide maximum rigidity.
- F. In the case of gravity discharge to sewer as in Drawing No 12 and Drawing No 13, pages 28 and 29, the pipeline should have a continuous fall. In these installations SWV pipe should be used.
- G. In situations where a fall to sewer is unable to be obtained (or not practical) a pit must be installed nearby to receive the discharged effluent from the separator. The effluent is then discharged to sewer by means of an automatic submersible pump as shown in Drawing No 15, page 31. In these installations PVC pressure pipe should be used and discharged over a suitable tundish.
- H. In both situations an air gap must always be provided at the point of entry to the sewer as shown.
- I. Entry to sewer may be either into a tundish or over a grate. In the case of the latter, a hole should be cut to accommodate the pipe to avoid splashing. Refer to drawing No 8, page 23.
- J. If connecting directly into a sewer stack, a pot gully should be installed where needed in accordance with local authority regulations.
- K. If the discharge line from the separator is longer than 6 metres a suitable vent and cowl must be installed. In the case of SMV pipelines longer than 6 metres expansion joints must be used at regular intervals as specified by regulatory authorities.
- L. Unions are to be fitted to the water inlet, water outlet and oil outlet of the separator to allow for ease of disconnection in the event of relocating the unit. Similar connections i.e. unions, camlocks, flanges etc are to be installed on the suction line to the pump and discharge line from the pump to allow ease of disconnection for service and maintenance.

Installation

ADDITIONAL INSTRUCTIONS

- A. External separator installations must be contained by bunds or other approved methods to prevent leaks, spills and overflows draining directly into the sewer. Bunds must be big enough to contain at least 110% of the volume of the largest storage.
- B. A tap (hose cock) must be installed within five metres of any pre-treatment equipment and a backflow prevention device must be fitted to the inlet side of the hose cock.
- C. The plumber must ensure that the site has adequate backflow prevention. He will need to comply with local sewer authority's Backflow Prevention Policy. This will mean that he must arrange for the installation of a backflow containment device at all the water meters servicing the property.
- D. All plumbing and drainage work must comply with AS3500 National Plumbing and Drainage Code.

INSTALLATION OF LEVEL FLOATS

- A. Cut a length of 32 mm orange/grey conduit of nearly equal length to the Depth of pit.
- B. Cut 1 "notch" or V section in to conduit as shown on page 22.

The spacing of this notch will depend of the size of the tank and length of suction line.

OIL SKIMMERS

Oil skimmers are set by moving the inner sleeve in the vertical plane to about 5 mm above the water level. To set the oil skimmers the tank should first be filled with clean water and the pump started in accordance with the manufacturer's recommendation. With effluent flowing over the exit weir the oil skimmers should then be set to a level as recommended above.

STARTING UP & COMMISSIONING

Before starting up, make certain that the separator is firmly anchored to plinth and that all pipework and connections are properly supported and secure.

Installation

KWIKFLO DIAPHRAGM PUMPS & PIPEWORK

1. Install the pump, level and secure, using the holes in the baseplate.
2. For liquids other than water being pumped, viscosity, specific gravity and solids in suspension must also be taken into account and it may be necessary to go to a larger pipe or hose than specified.
3. Keep pipework as short and direct as possible.
4. Avoid the use of elbows and check valves.
5. Gate valves must not be installed in the suction or delivery pipework unless an isolation valves. Under no circumstances should the flow be attempted to be controlled by a gate valve.
6. It is recommended that unions are to be used on the suction and discharge sides of the pump to facilitate easy removal for servicing.
7. For suction and discharge pipework we recommend using PVC pressure pipe of minimum pressure rating Class 9 and minimum size of 32 mm refer to table on the next page.
8. Suction and Delivery pipework should have their own support brackets.
9. At least 3 metres of reinforced flexible hose such as Heliflex or similar are to be used between the pump and any fixed pipework where practical.
10. Suction lines should not exceed 7.6 metres in length. When flexible hose is used it should be reinforced PVC or rubber suction hose such as Heliflex or similar.
11. A suction hose strainer should be fitted to screen out larger solids and to stop the hose sucking into the bottom or side of the pit or sump. When using PVC pressure pipe, the suction strainer should be left off.
12. We recommend reinforced PVC or rubber hose for delivery hose to avoid kinking & collapsing.
13. Where the pump is working against a vertical discharge head, pipework should rise from the pump and then fall away or run horizontally.
14. To minimise potential problems with air leaks only use heavy duty hose clamps.

WARNING

PUMPS MUST BE PROTECTED FROM THE WEATHER AND ACCIDENTAL HOISING

KWIKFLO DIAPHRAGM PUMPS & PIPEWORK

1. All electrical work to be carried out by licensed electrical contractors to AS3000.
2. Electric motors should be wired in accordance with the manufacturer's specifications
3. Three phase motors need overload protection wired into the circuit.
4. Single phase motors normally have built in overload protection but if not it should be wired into the circuit.
5. Electric motors fitted are totally enclosed fan cooled but do require protection from the weather and being hosed with water.
6. Always allow adequate ventilation for motor cooling and never restrict air flow to the cooling fan.

Installation

GEARBOX

1. Remove vent plug from oil filler cap before start up.
2. Check oil is visible in sight glass before start up.
3. Recommended oil – Shell Omala 320 or Castrol Alpha SP320.

RECOMMENDED LENGTHS AND DIAMETERS OF PVC PIPE/HOSE FOR KWIKFLO DIAPHRAGM PUMPS

MODEL	PUMP SIZE	SUCTION LENGTH	PIPE INTERNAL DIAMETER	DISCHARGE LENGTH	PIPE INTERNAL DIAMETER
KDP25-100	25mm	0-5 Metres	25mm	0-10 Metres	32mm
		5-10 Metres	32mm	10-20 Metres	40mm
KDP25-150	25mm	0-5 Metres	25mm	0-10 Metres	32mm
		5-10 Metres	32mm	10-20 Metres	40mm
KDP32-200	32mm	0-5 Metres	32mm	0-10 Metres	40mm
		5-10 Metres	40mm	10-20 Metres	50mm
KDP38-300	38mm	0-5 Metres	40mm	0-10 Metres	50mm
		5-10 Metres	50mm	10-20 Metres	65mm
KDP50-600	50mm	0-5 Metres	50mm	0-10 Metres	65mm
		5-10 Metres	65mm	10-20 Metres	80mm
KDP76-120	76mm	0-5 Metres	80mm	0-10 Metres	100mm
		5-10 Metres	80mm	10-20 Metres	100mm

PLEASE NOTE

Correct rotation is clockwise viewed from the non drive end of the motor. Incorrect rotation will cause damage to the pump and void pump warranty. Refer to motor manufacturer's wiring instructions before running the pump. This is especially important with three phase motors.

Installation Drawings

TYPICAL ARRANGEMENT - STANDARD INSTALLATION

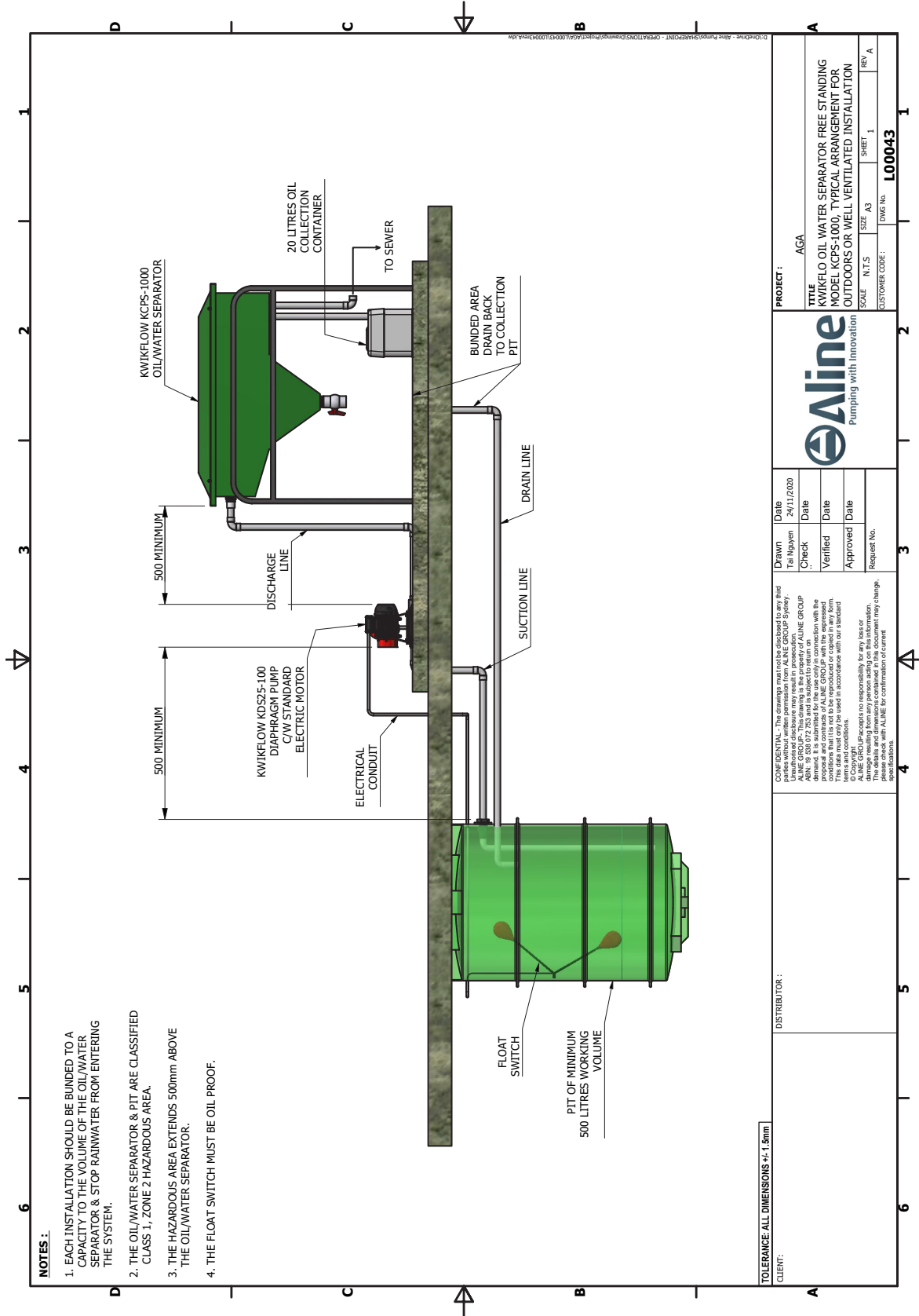

Installation Drawings

GENERAL ARRANGEMENT - EXPLOSION PROOF INSTALLATION W/ CONTROL PANEL

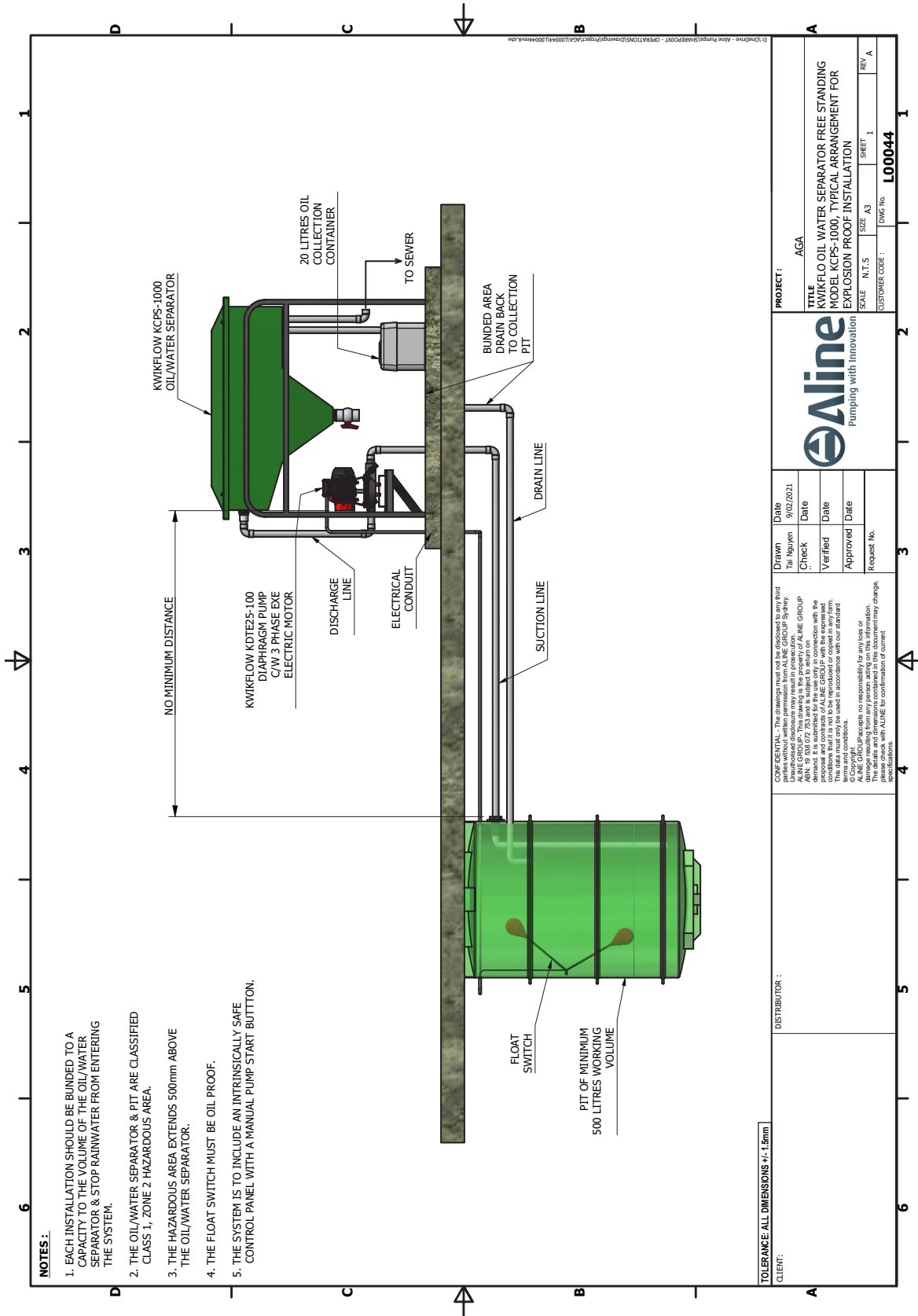

Installation Drawings

TYPICAL ARRANGEMENT - WHEN PUMPING TO SEWER

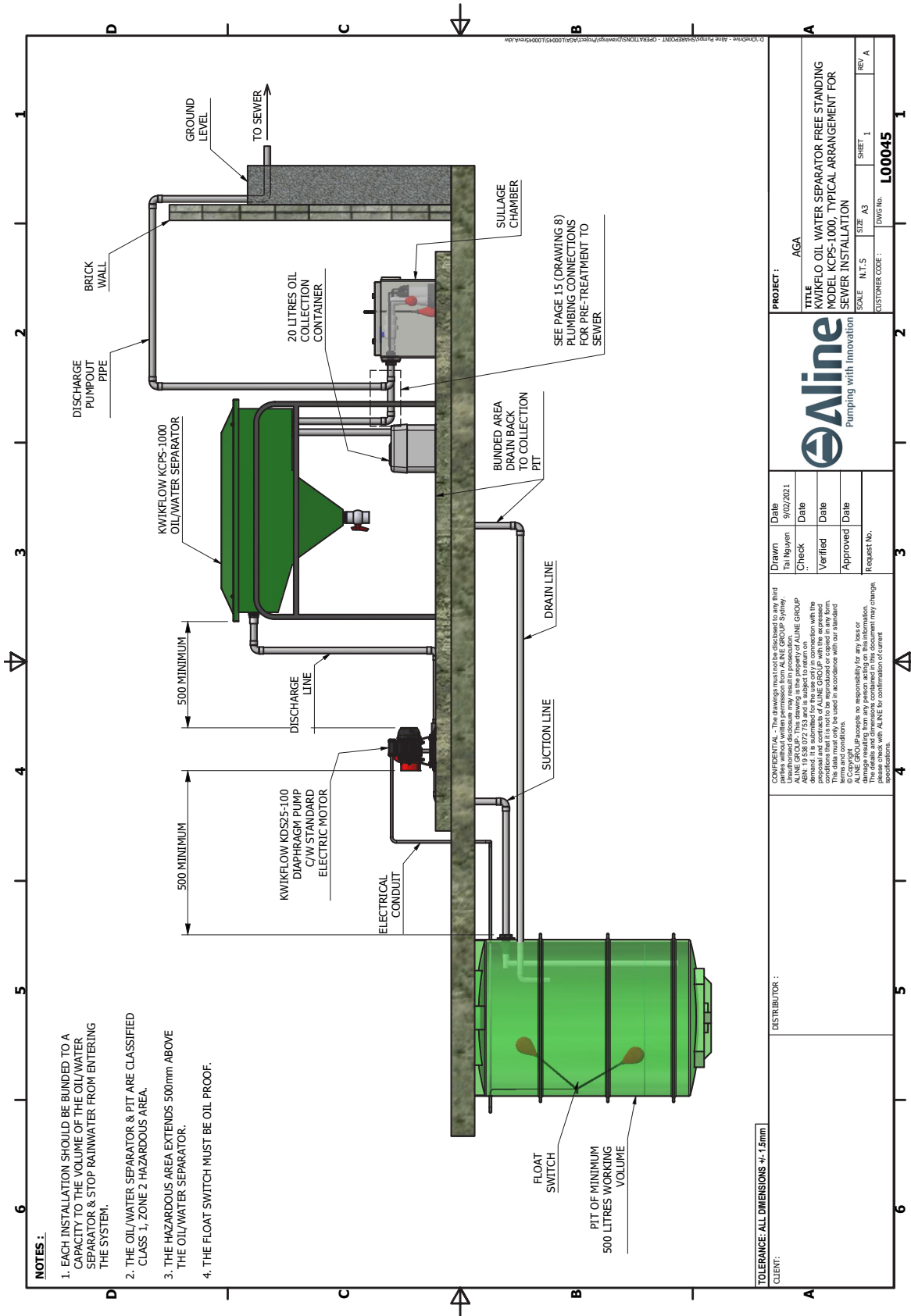

Installation Drawings

FLOAT INSTALLATION IN COLLECTION PIT

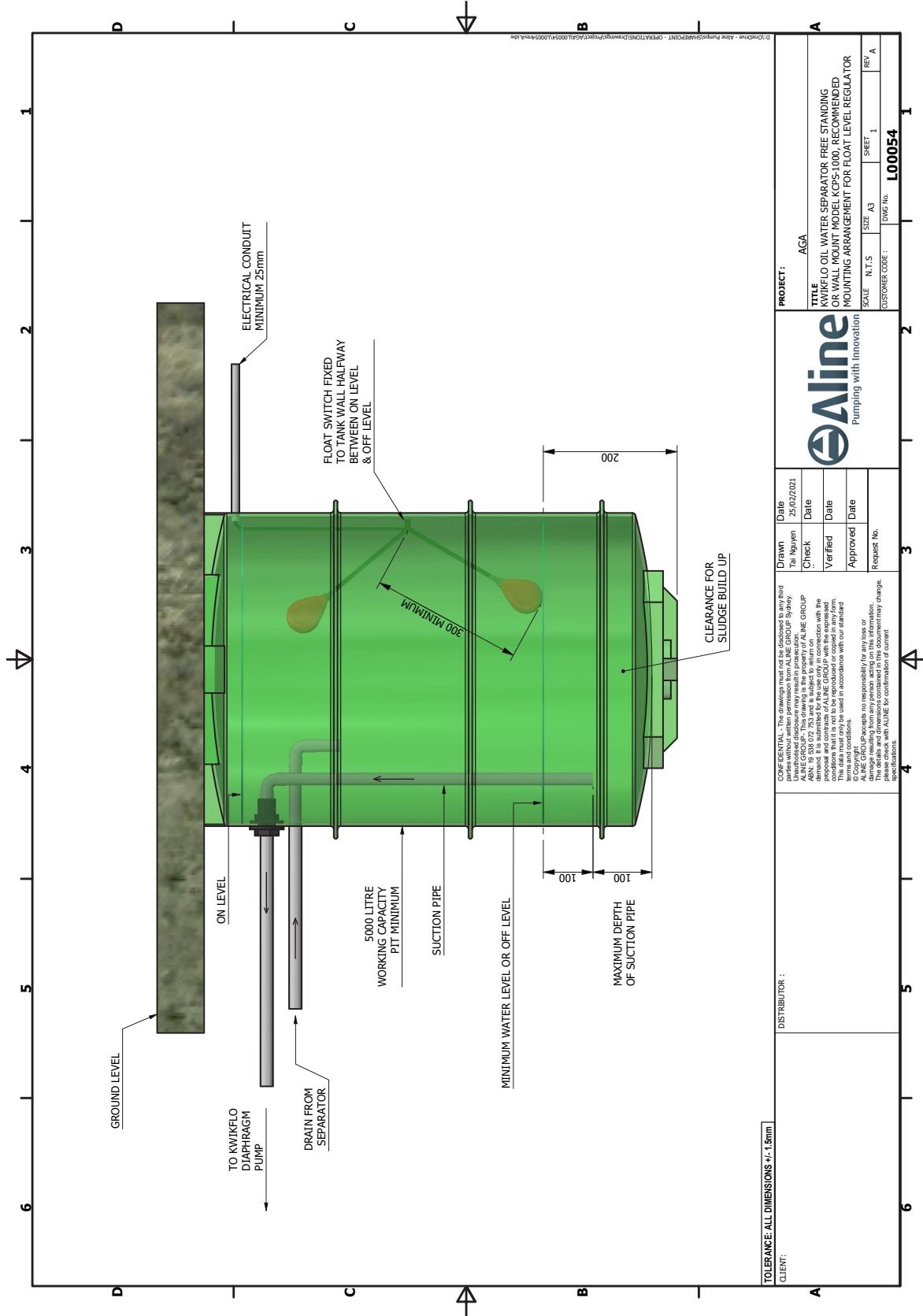

Installation Drawings

TYPICAL ARRANGEMENT - SEWER CONNECTION

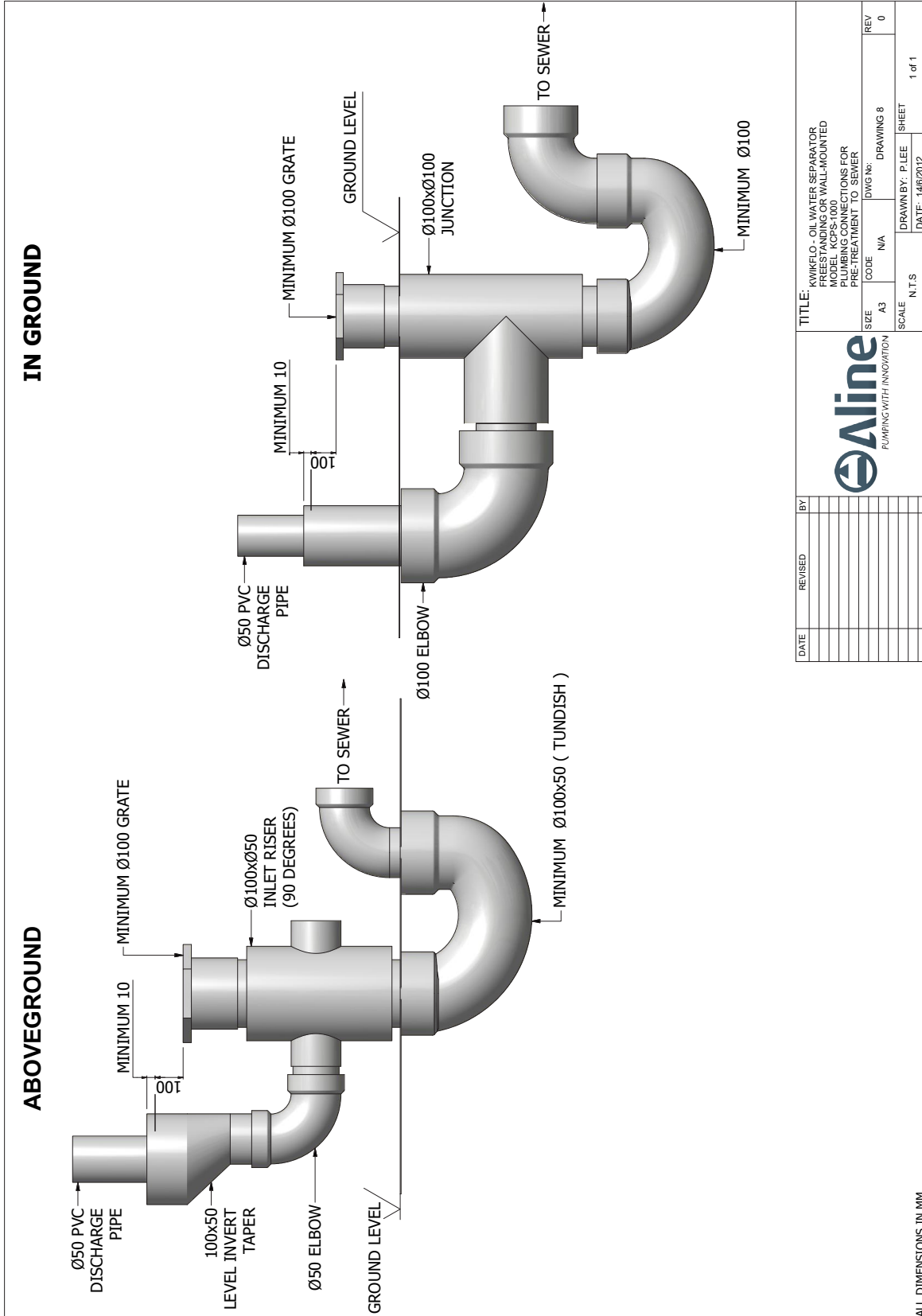

Installation Drawings

TRADE WASTE SAMPLING POINT

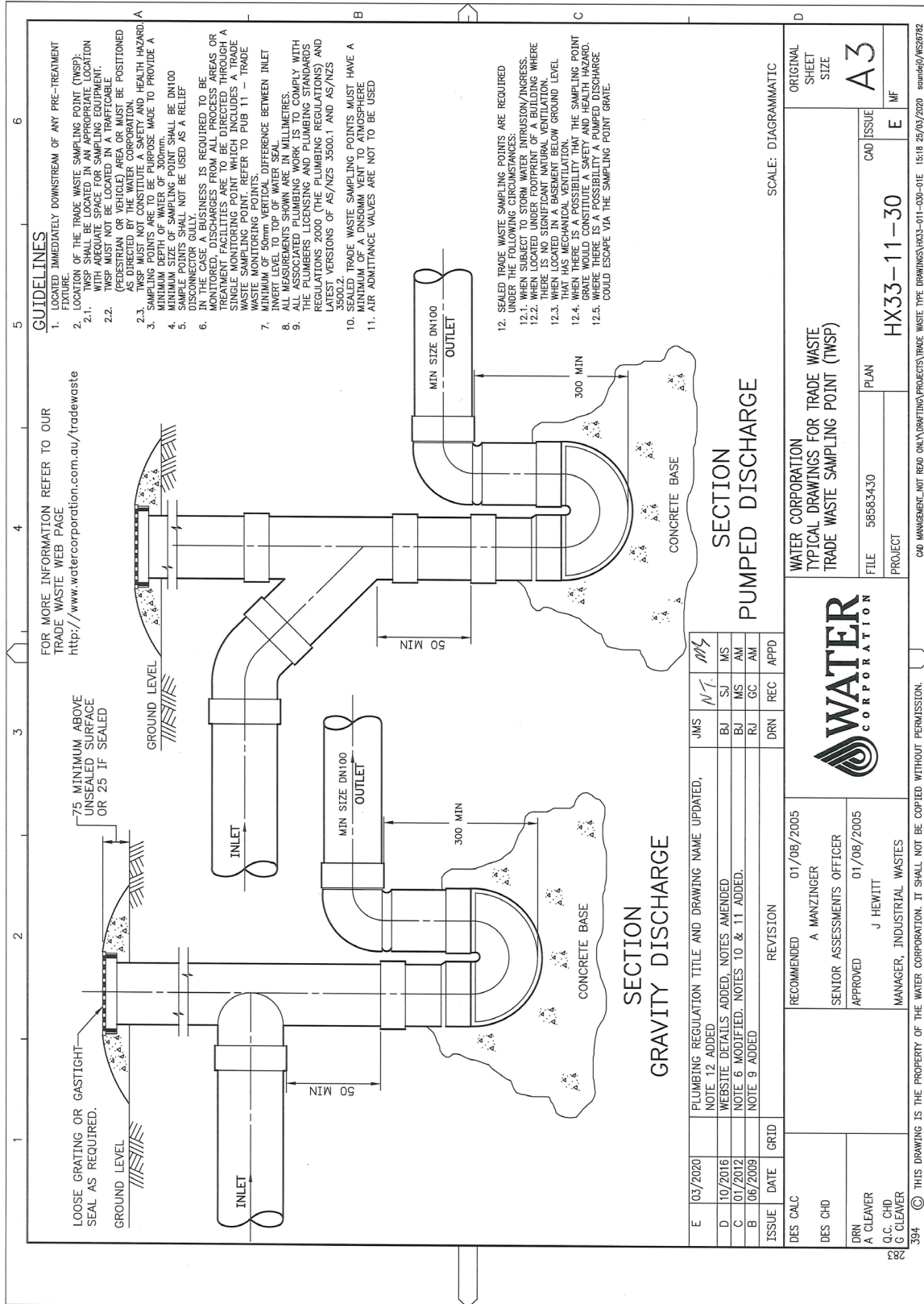

Installation Drawings

ELECTRICAL CONNECTIONS

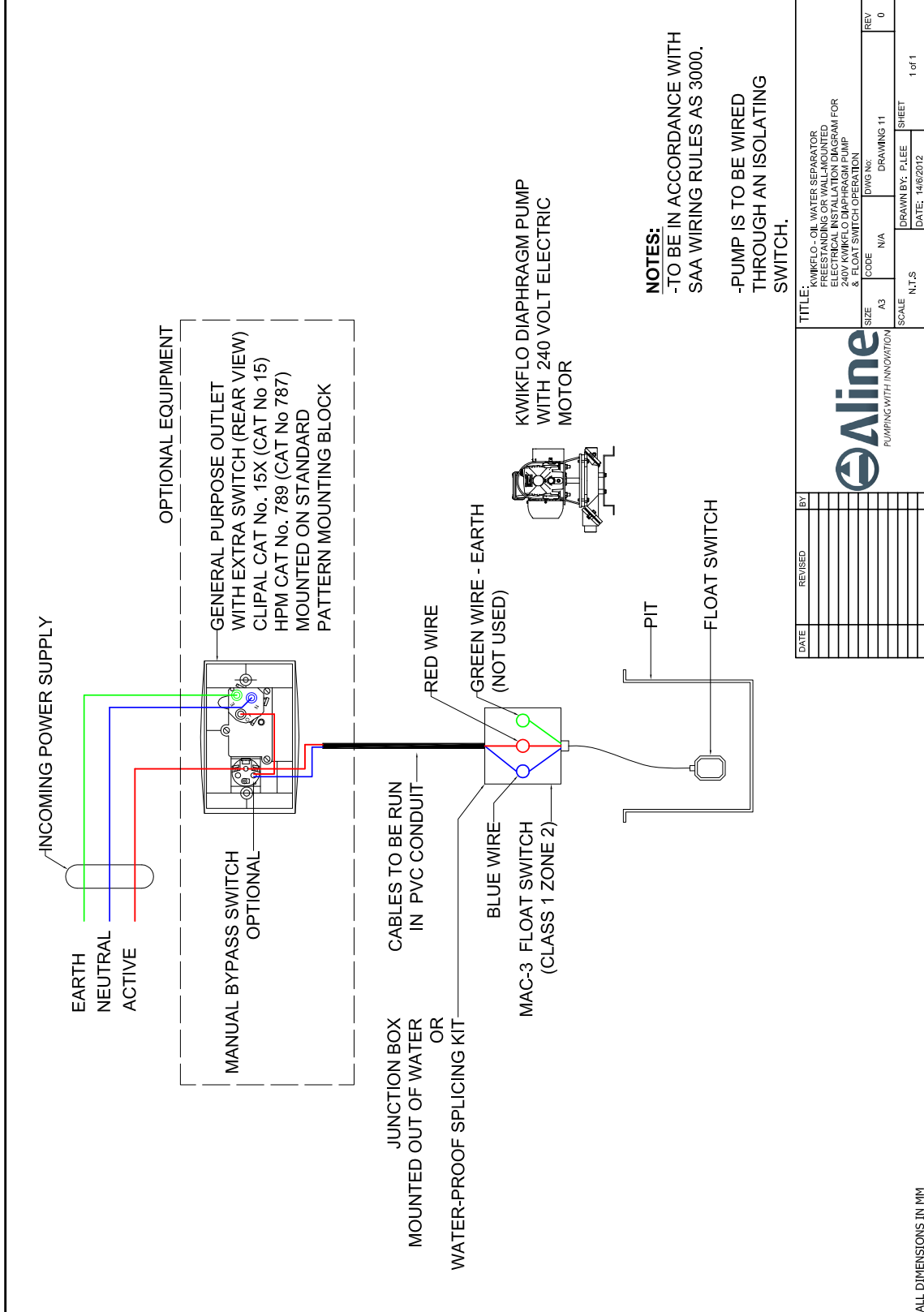

Installation Drawings

ELECTRICAL CONNECTIONS

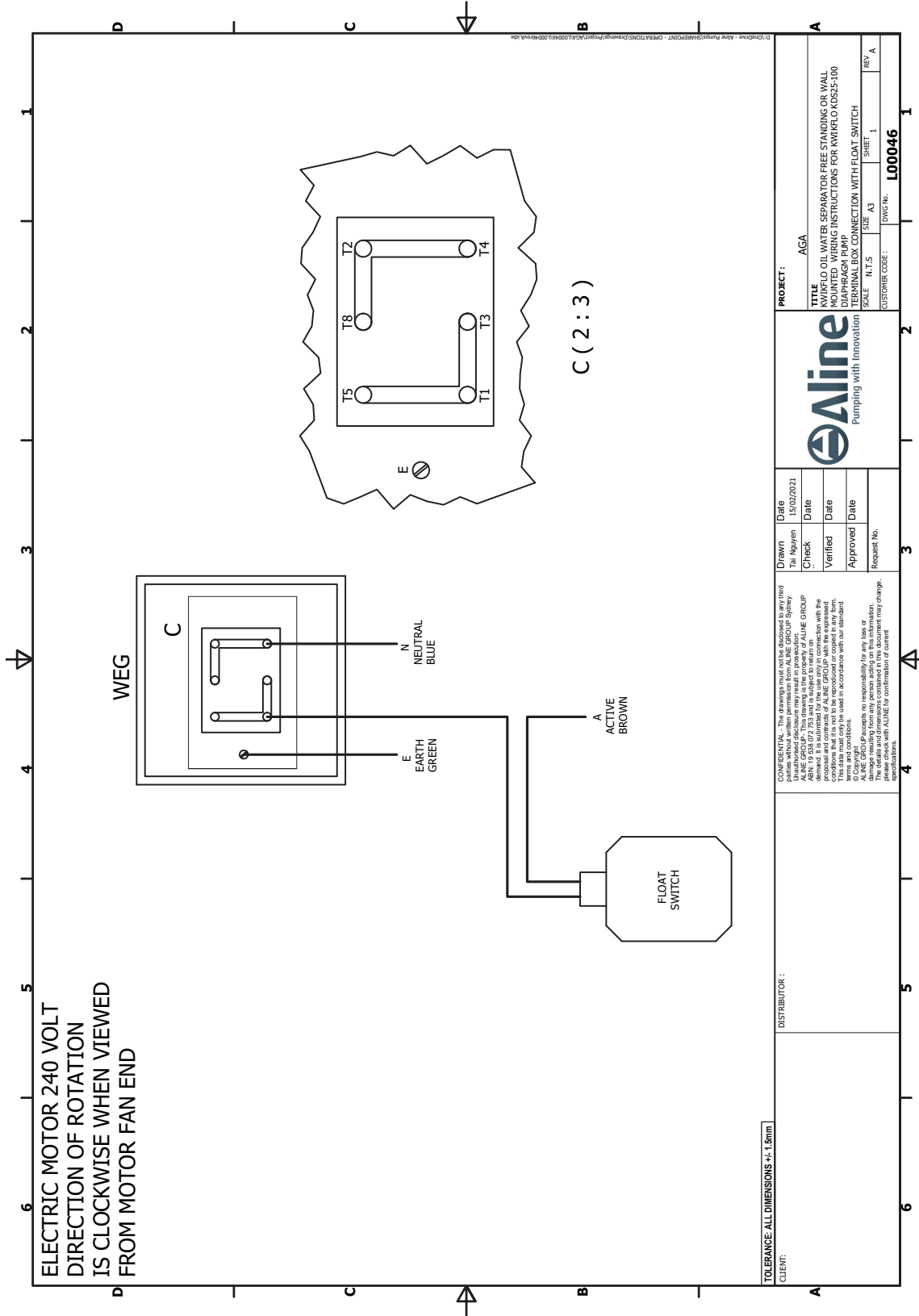

CLIENT: TOLERANCE: ALL DIMENSIONS $\pm 1.5\text{mm}$		DISTRIBUTOR: CONFIDENTIAL - The drawings must not be disclosed to any third party without the prior written consent of ALINE GROUP Sdn Bhd. Unauthorised disclosure may result in prosecution.		Drawn: Tai Nguyen Check: Verified: Approved: Request No.		Date: 15/02/2021	
PROJECT: AGA		DATE:		DATE:		DATE:	
TITLE: KWIKFLO OIL-WATER SEPARATOR-FREE STANDING OR WALL MOUNTED WIRING INSTRUCTIONS FOR KWIKFLO KOS25-100 D/PHRAGM PUMP		SCALE: N.T.S		SIZE: A3		REV: A	
TERMINAL BOX CONNECTION WITH FLOAT SWITCH		SHEET: 1		DWG No.: L00046		REV: A	
Customer Code:		Request No.:		Approved:		Request No.:	

Technical Data

KWIKFLO DIAPHRAGM PUMPS - DATASHEET

MODEL	FLOWRATE (L/HR)	VOLTS/ PHASE	MOTOR KW	MOTOR RPM	GEARBOX PULLEY	MOTOR PULLEY	STROKES/ MIN
KDS25-100	1000	240/1	0.37	1380	2-3/4"	1-3/4"	29
KDT25-100	1000	415/3	0.37	1365	2-3/4"	1-3/4"	29
KDS25-150	1500	240/1	0.37	1380	2-3/4"	2-3/4"	29
KDT25-150	1500	415/3	0.37	1365	2-3/4"	2-3/4"	29
KDS32-200	2000	240/1	0.37	1380	3"	2-1/2"	38
KDT32-200	2000	415/3	0.37	1365	3"	2-1/2"	38
KDS38-300	3000	240/1	0.75	1410	3-1/2"	2-1/2"	34
KDT38-300	3000	415/3	0.75	1410	3-1/2"	2-1/2"	34
KDS50-600	6000	240/1	1.1	1410	3-1/2"	3"	40
KDT50-600	6000	415/3	1.1	1445	3-1/2"	3"	41
KDS76-120	12000	240/1	1.5	1420	3-1/2"	3"	41
KDT76-120	12000	415/3	1.5	1430	3-1/2"	3"	41

KDS DIAPHRAGM PUMP SPECIFICATION

MODEL	SIZE	CAPACITY CLEAN WATER L/M	SUCTION LIFT (METRES)	DISCHARGE HEAD (METRES)	SOLIDS SIZE (MM)	WEIGHT (KG)
KDP25-100	25mm	16	7.5	6	15	25
KDP25-150	25mm	25	7.5	6	15	25
KDP32-200	32mm	33	7.5	6	20	30
KDP38-300	38mm	50	7.5	6	25	42
KDP50-600	50mm	100	7.5	6	35	55
KDP76-120	76mm	210	7.5	6	50	72

Technical Data

DIMENSIONS & SPECIFICATION

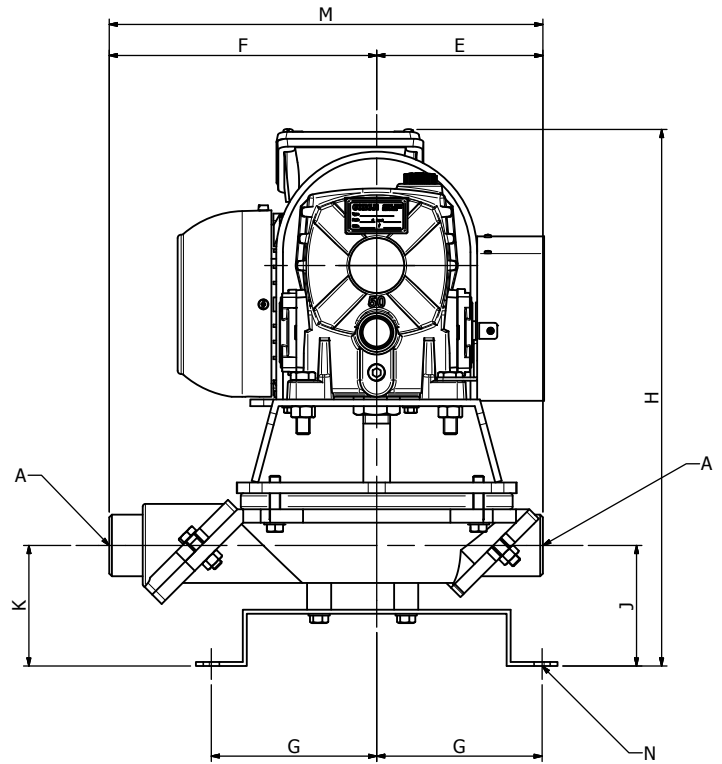
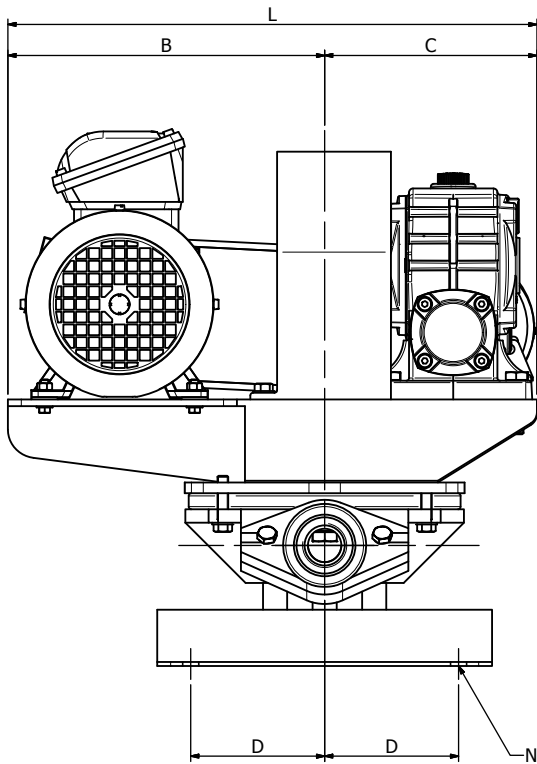

KDS DIAPHRAGM PUMP DIMENSIONS

SIZE	A	B	C	D	E	F	G	H	J	K	L	M	N
KDP25	25	275	155	100	110	205	125	389	95	100	430	315	12
KDP32	32	275	175	100	140	220	125	410	105	105	450	380	12
KDP38	38	270	175	100	170	240	125	480	110	110	465	410	12
KDP50	50	275	200	100	195	280	125	530	115	115	475	475	12
KDP76	76	375	230	100	230	350	125	590	115	115	605	580	12

Technical Drawings

KCPS-1000 FREE STANDING

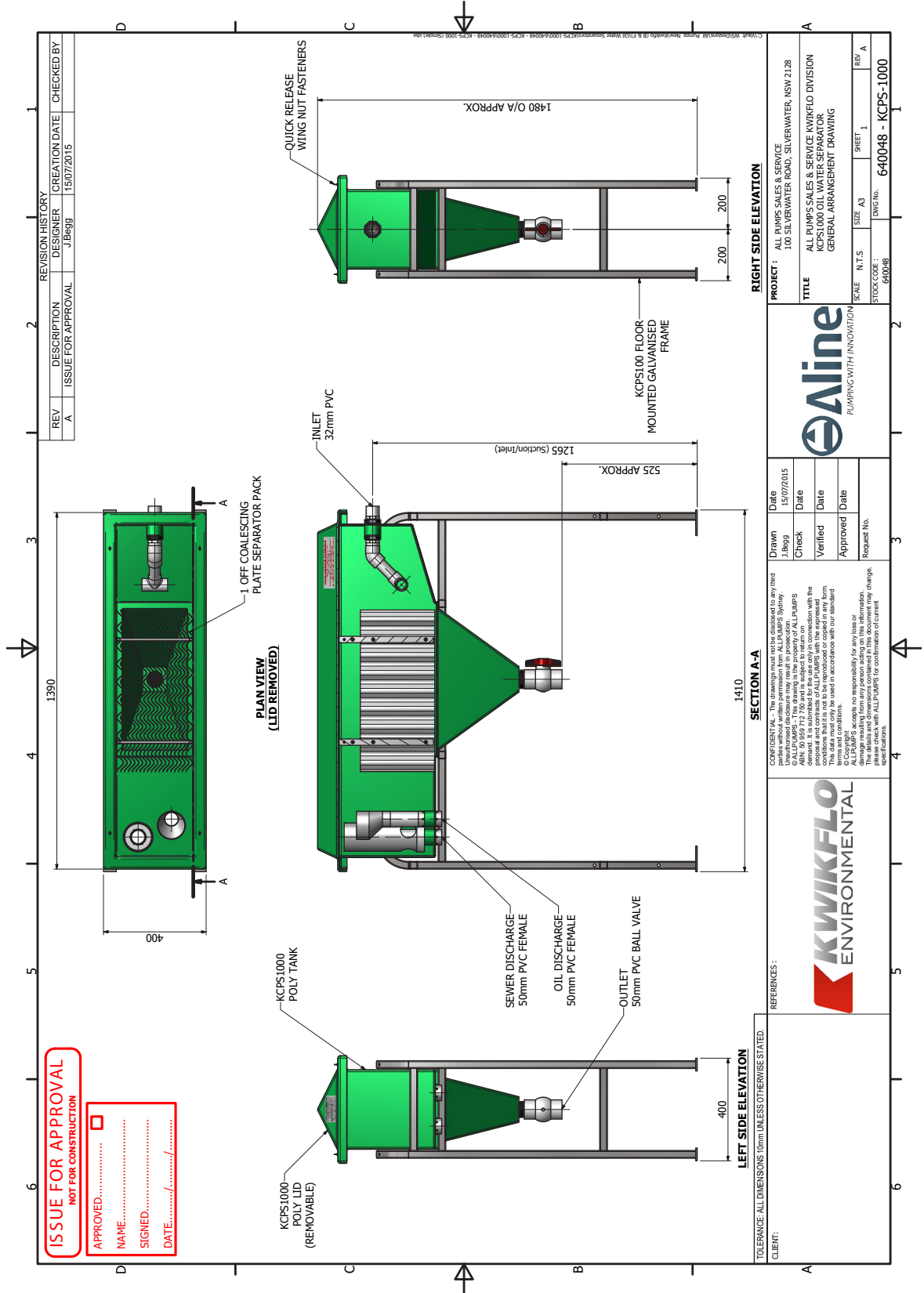

Technical Drawings

KCPS-1000 WALL MOUNT

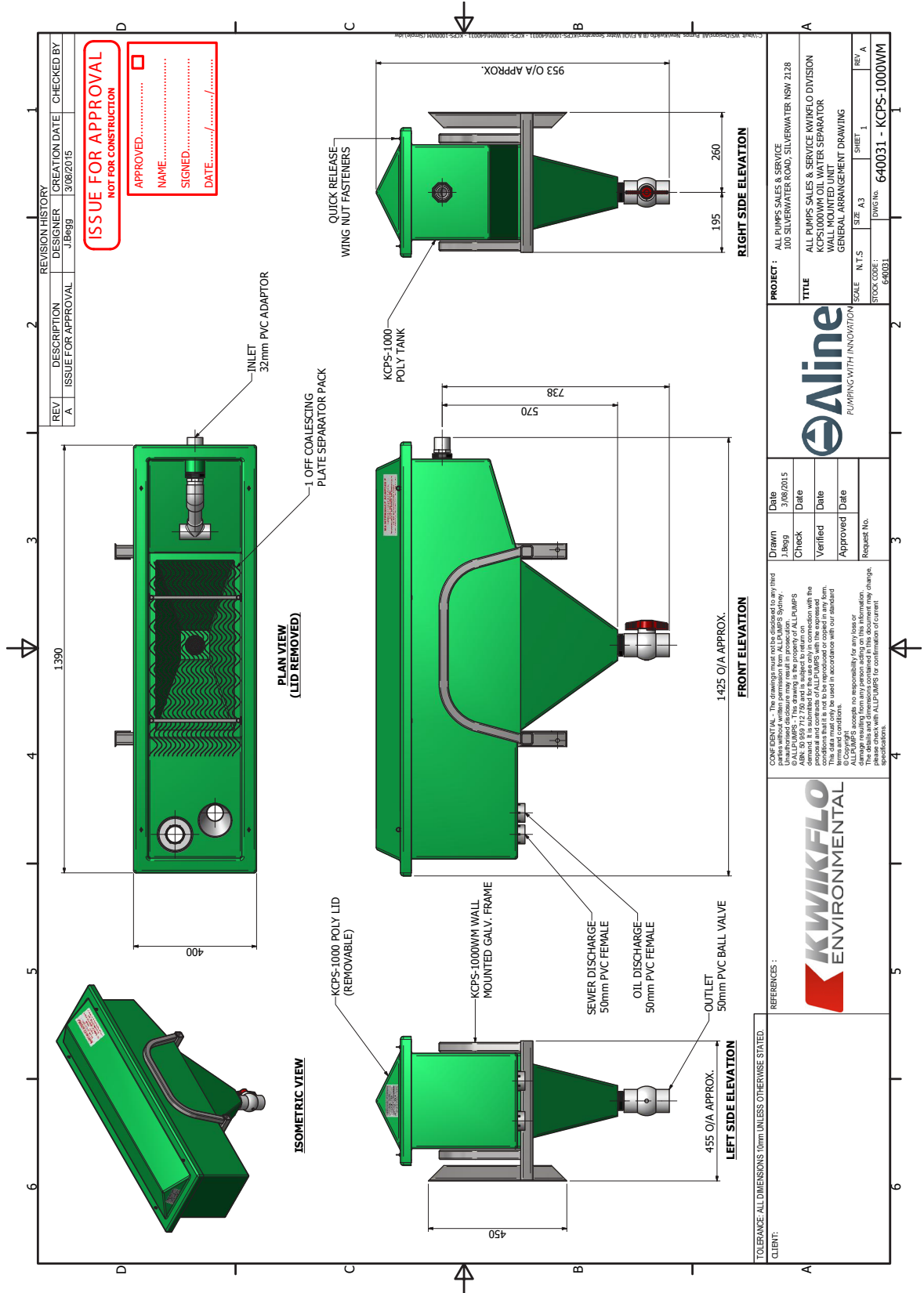

Technical Drawings

KCPS-1500 FREE STANDING

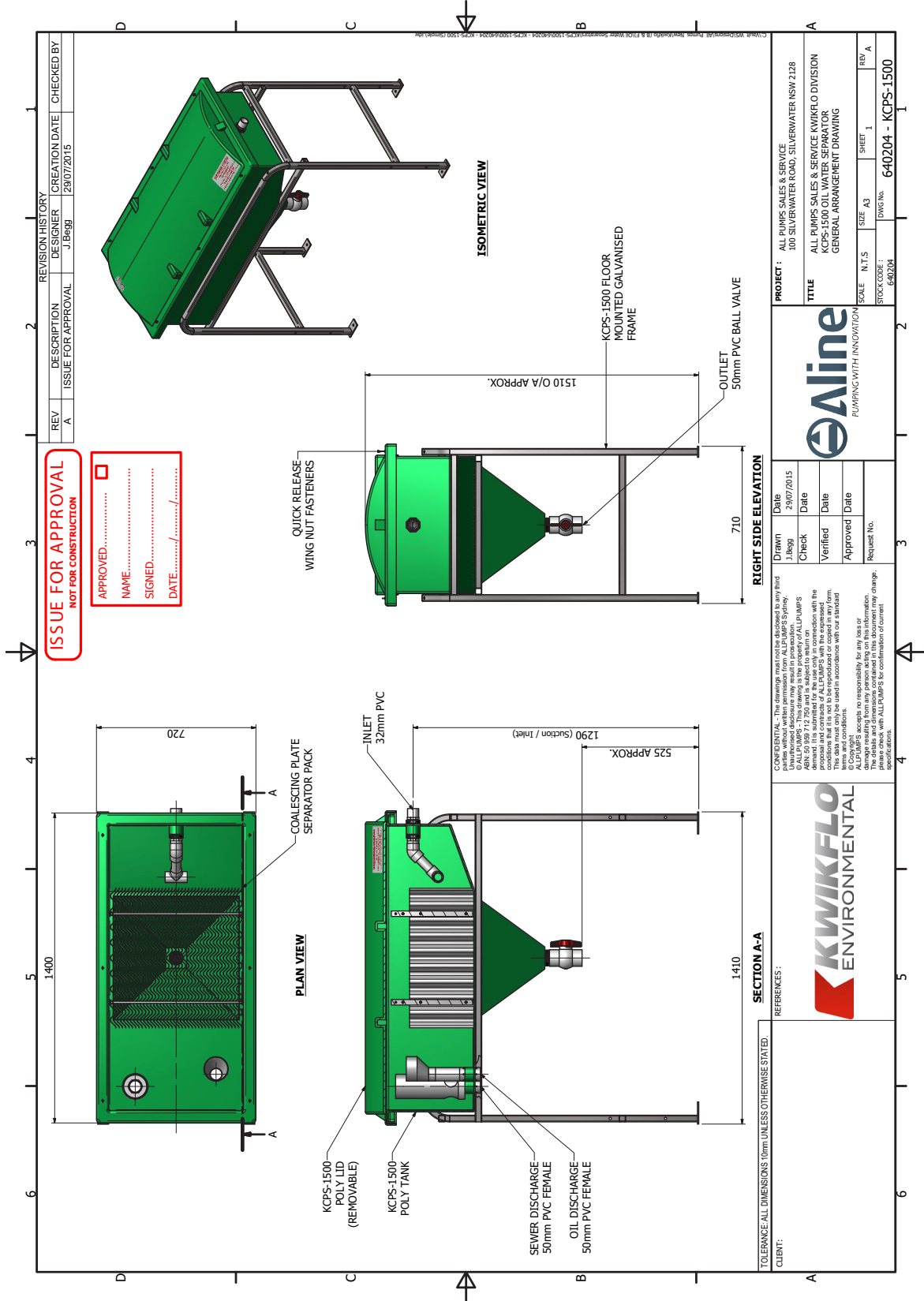

Technical Drawings

KCPS-2000 & KCPS-3000 FREE STANDING

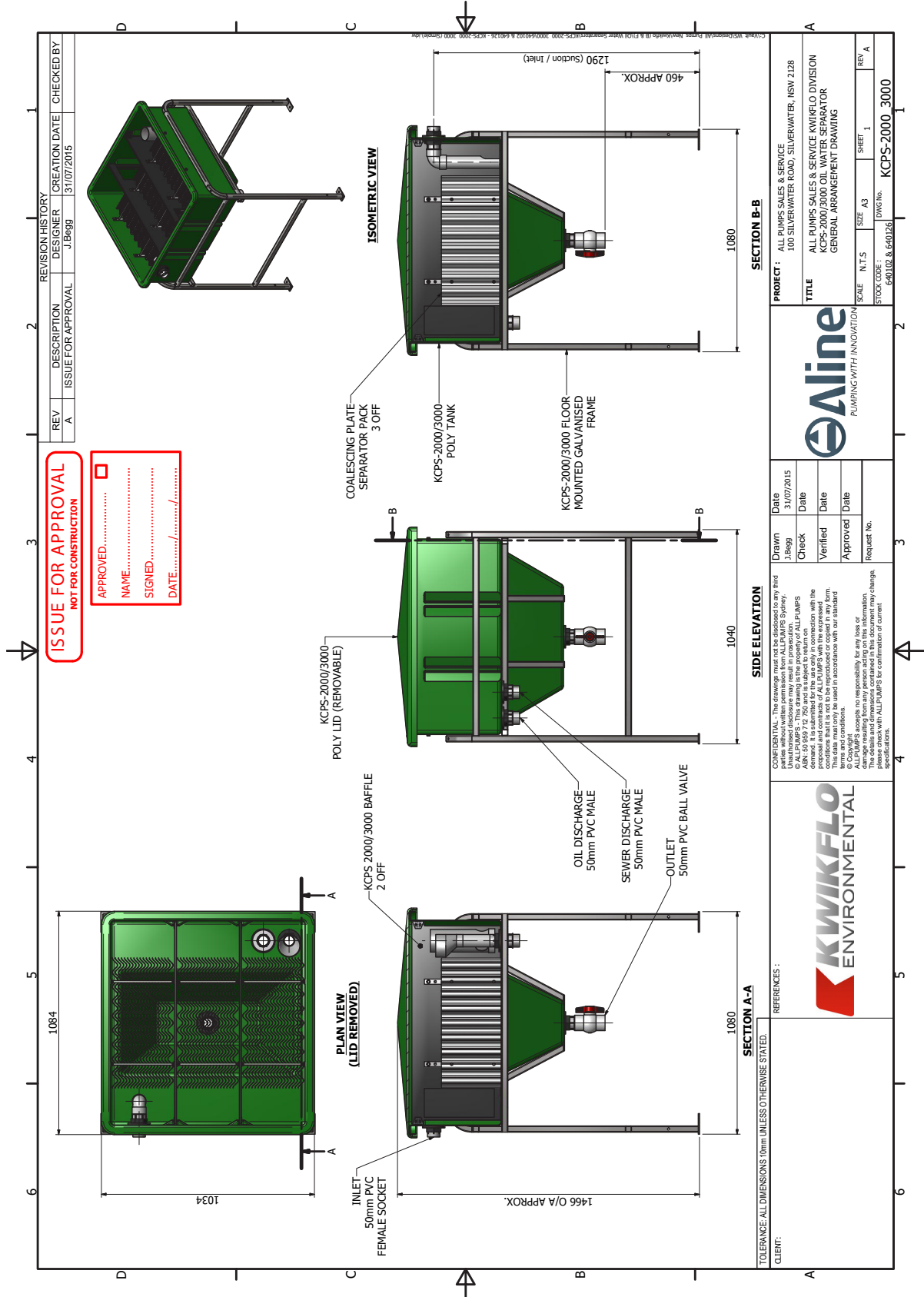

Technical Drawings

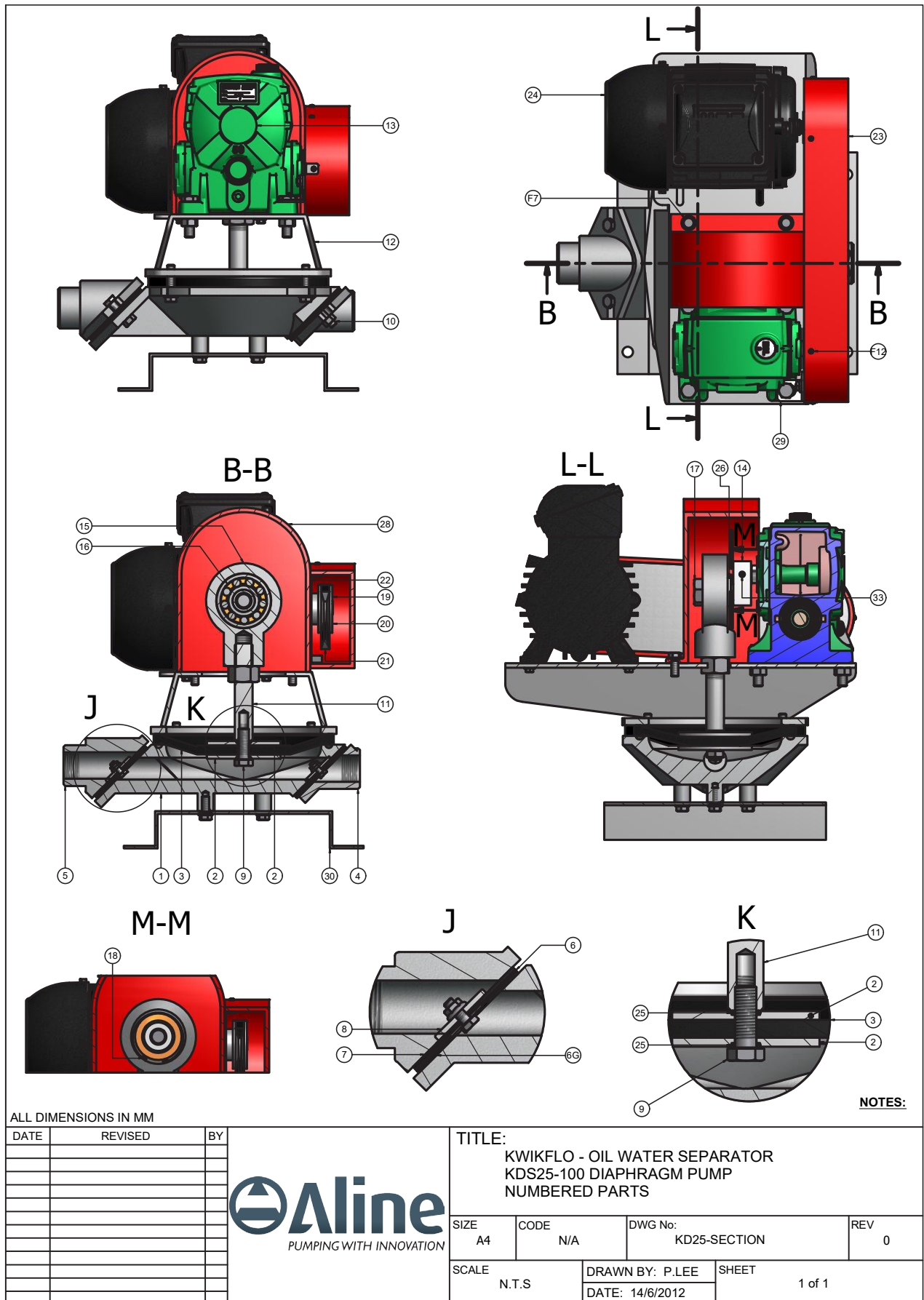

Technical Drawings

PARTS LIST

NO.	DESCRIPTION
01	KWIKFLO ALUMINIUM BOWL
02	CAD PLATE STEEL DIAPHRAGM PLATE
03	NITRILE DIAPHRAGM
04	ALUMINIUM SUCTION PORT
05	ALUMINIUM DISCHARGE PORT
06	STAINLESS STEEL VALVE SEAT
06G	NITRILE VALVE SEAT GASKET
07	NITRILE FLAP VALVE
08	WEIGHT SET
09	DIAPHRAGM PLATE BOLT
10	SUCTION PORT STUD
11	CONNECTING ROD
12	KWIKFLO DRIVE SUPPORT HOUSING
13	KWIKFLO CAST IRON GEAR BOX
14	KWIKFLO ZINC PLATE STEEL ECCENTRIC BLOCK
15	ECCENTRIC BEARING HOUSING
16	ECCENTRIC BEARING
17	ECCENTRIC BOLT & WASHER
18	HIGH TENSILE CIRCLIP
19	GEAR BOX PULLEY
20	MOTOR PULLEY
21	VEE BELT
22	PULLEY GUARD BACK PLATE
23	PULLEY GUARD-PLASTIC
24E	ELECTRIC MOTOR 415 VOLT Exe
24S	ELECTRIC MOTOR 240 VOLT
24T	ELECTRIC MOTOR 415 VOLT
25	DIAPHRAGM PLATE O-RING
26	ECCENTRIC BOLT SPACER
28	ECCENTRIC GUARD-PLASTIC
29	PULLEY GUARD BACKPLATE SUPPORT BRACKET
30	KWIKFLO GALVANISED STEEL BASE PLATE

SERVICE KITS

STOCK CODE	DESCRIPTION
680090	KWIKFLO KDP25-100 FLUID SERVICE KIT
680414	KWIKFLO KDP25-150 FLUID SERVICE KIT
680176	KWIKFLO KDP-32 FLUID SERVICE KIT
680250	KWIKFLO KDP-38 FLUID SERVICE KIT
680332	KWIKFLO KDP-50 FLUID SERVICE KIT
680412	KWIKFLO KDP-76 FLUID SERVICE KIT

Maintenance

MAINTENANCE OF THE SEPARATOR UNIT

Only qualified and competent personnel should carry out maintenance of the Kwikflo KCPS-1000 Coalescing Plate Separator.

DAILY MAINTENANCE

- Remove any obstruction from the grates of the pit and drains
- Visually inspect the pit to ensure that the float switch(es) is operational and free to move
- Visually inspect the separator and remove any floating solid matter which may block the plate packs.
- Visually inspect the system for any leakages. If any are detected report to the Maintenance Manager.
- Visually inspect the discharge effluent. If the effluent is not typical of normal discharge take a sample and record the time and details of the previous work in the washbay including the type of detergent used.
- Check that the pump is operational. If it is not, report to the Maintenance Manager.

WEEKLY MAINTENANCE

The same procedure as for daily maintenance to be followed.

- Thoroughly wash down the washbay or vehicle workshop.
- Check the gear oil level in the reduction gear box.
- Check the levels in the waste oil drum and arrange for disposal if necessary.
- Check the level of the sludge in the pit and if required arrange for the pit to be pumped out by a licensed liquid waste transporter.

THREE-MONTHLY MAINTENANCE

- The same procedure as for weekly maintenance to be followed.
- Clean the separator as per the detailed instructions overleaf.
- Clean out the collection pit.
- Disconnect the power source to ensure that the pump will remain inoperative.
- Remove the lid of the separator.
- Lower the oil skimmer to remove all the oil from the water surface.
- Drain the separator by opening the sludge valve in the bottom of the solids hopper. Note where the sludge is to go as per the detailed instructions overleaf.
- Release quarter-turn fasteners on both sides of plate packs.

Maintenance

- Remove plate pack stacks gripping the handles provided. Caution: Plate packs when full of sludge could weigh up to 30 kg and appropriate lifting equipment may need to be used.
- Drain the separator by opening the sludge valve in the bottom of the solids hopper. Thick sludge is to be put in the rubbish. Semi-liquid sludge is to be hosed into the pit.
- Inspect and remove any large items that have not drained through the valve. These large items are to be put in the rubbish.
- Hose down the interior of the tank with the ball valve still open. All waste is to be hosed into the pit.
- Hose through the plate stacks with high pressure water. Do not dismantle the stacks. All waste is to be hosed into the pit.
- Check the level of the sludge in the pit and if required arrange for the pit to be pumped out by a licensed liquid waste transporter.
- Replace the plate pack stacks into their original positions. Make sure retaining bars are adjacent to long sides of unit.
- Refill the separator with potable water and restart the system.
- Reset the oil skimmer to the original position of approximately 5 mm above the operating water level.
- Check that the unions are tight and that there are no leaks.
- Replace the lid and secure with quick release fasteners.
- Check gear box oil and top up if required.

CLEANING FREQUENCY

Installation conditions will determine the regularity of maintenance intervals, ie; the quality of the influent that the separator is treating. It is recommended that initially maintenance be carried out as described. However, it may need more regular servicing where there is excessive silt, debris and sludge entering the separator.

MAINTENANCE OF THE DIAPHRAGM PUMP

Replacement of Diaphragm

As the diaphragm is a wearing part it will need to be replaced as often as individual conditions dictate. The diaphragm must be replaced if it is torn, split or leaking. Replacement diaphragms are available from Aline Group Australasia in a "Wet Service Kit" which also contains flap valves, vee-belt and gaskets (Product Code KD25-KIT).

1. Disconnect power at supply.
2. Remove all four casing.
3. Lift drive support housing (No.12) complete with motor (No. 24) and gearbox (No.13) to one side. N.B TAKE CARE TO AVOID DAMAGE TO ELECTRICAL CONNECTION.
4. With access now available to diaphragm (No.3) remove lower bolt (No.9) washer (No.10) and diaphragm plate (No.2). N.B BE SURE UPPER BOLT (No.2) STAYS IN ORIGINAL POSITION.
5. Remove and replace diaphragm (No.3) with writing on new diaphragm (No.3) facing upwards. Re-fit lower diaphragm plate (No.2) making sure the inner lip edge on the diaphragm (No.3) is located in the corresponding grooves in the diaphragm plate (No.2). Then re-fit lower washer (No.10) and bolt (No.9) and tighten.

Maintenance

6. Reposition drive support housing (No.12) onto bowl (No.1) and locate outer lip edge of diaphragm in corresponding grooves in bowl and drive support housing.
7. Re-fit all four casing bolts and tighten evenly. N.B DO NOT OVERTIGHTEN THESE BOLTS. (To be tightened to 12 N.m).
8. Re-connect power supply and check operation.
9. The diaphragm pump must be drained every 3 months and inspected for wear and tear of diaphragm, flap valves and gaskets.

REPLACEMENT OF FLAP VALVES

Before attempting to replace the flap valves it should be noted that the flap valve assemblies (No. 7) for the suction and discharge ports are identical. Assembly order should be as per diagram No. 9b page 24. When the flap valve assembly (No.7) is fitted to the suction of the pump the flap valve Assembly (No.7) will be adjacent to pump casing (No.1) however when flap valve assembly (No.7) is fitted to the discharge of the pump the flap valve (No.7) will be adjacent to the discharge chamber (No.5).

1. Disconnect power at supply.
2. Disconnect pipework adjacent to faulty flap valve and corresponding chamber bolts.
3. Remove valve chamber (No.4-5).
4. Remove flap valve assembly (No.7) and check components for wear and replace accordingly.
5. Re-assemble flap valve assembly (No.7) as per diagram No. 9b page 24.
N.B WARNING: DO NOT OVERTIGHTEN.
Flap valve bolt to be wound in hand tight to weight.
Locking nut to be tightened to 14 N.m.
6. Re-fit flap valve assembly (No.7) and check flow directions. Suction valve should push into pump whilst discharge valve should lift up and both flap valves should re-seal automatically.
7. Re-fit corresponding valve chamber (No.4-5) and chamber bolts and tighten.
8. Re-connect pipework to valve chamber (No.4-5).
9. Re-connect power supply and check operation.

Warranty

The Kwikflo KCPS Coalescing Plate Separator and the Kwikflo KDP Diaphragm Pump are guaranteed to be free from defects in material or workmanship for five years from the date of shipment from Aline Group Australasia factory in Silverwater. The pump's electric motor is per manufacturer's given warranty (twelve months). No claim will be recognised for any allied defects in the collection tank that may have been apparent prior to installation, whether due to faults in manufacture or faults caused by transport and handling. Aline Group Australasia accept no responsibility for consequential damages or actions arising out of units not operated, installed or maintained in strict accordance with written instructions. It is the responsibility of the operator to ensure the unit is used with approval and operated to achieve the standards required by statutory authorities. Any claim that the oil/grease concentration is above the specified limit must be accompanied by an MBAS test result.

The obligation of this warranty, statutory or otherwise, is limited to replacement or repair at Parramatta factory, or at a point designated by Aline Group Australasia, of such part as shall appear to us, upon inspection to have been defective in material or workmanship. The warranty does not obligate Aline Group Australasia to bear the cost of labour or transportation charges in connection with replacement or repair of defective parts; nor shall it apply to a pump upon which repairs or alterations have been made unless authorised by Aline Group Australasia Sales & Service in writing.

No warranty is made in respect to electrical control panels, motors or trade accessories, such being subject to warranties of their respective manufacturers. Diaphragms and other consumables such as flap valves and gaskets are not included in the warranty. In no event shall Aline Group Australasia Sales & Service be liable for consequential damages or Contingent liabilities for consequential damages or contingent liabilities arising out of the failure of any Kwikflo Coalescing Plate Separator or parts thereof to operate properly.

NOTES

Ruled area for notes, consisting of multiple horizontal dashed lines.



PHONE: 1800 018 999 | EMAIL: pumps@alinepumps.com
OFFICE: 17 Burns Rd, Heathcote, NSW 2233 Australia
WEB: www.alinepumps.com