

Assembly and Installation Instructions Oil Water Separator KLsepa.compact

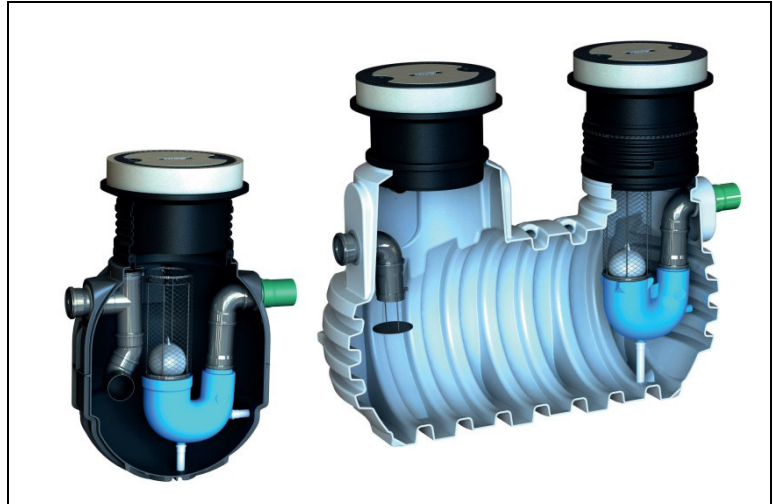
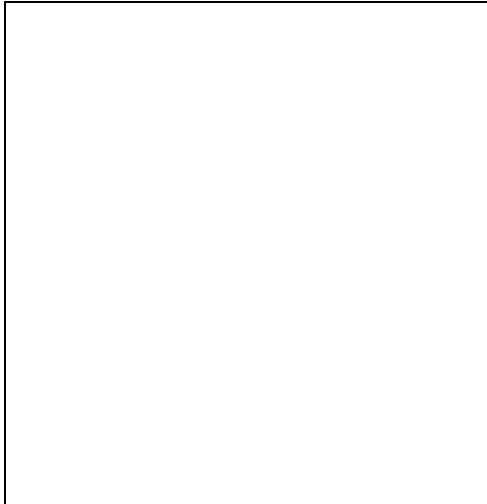

It is imperative to observe the items described in these instructions. In case of non-compliance, all warranty claims shall lapse. For all add-on items from GRAF, you shall receive separate installation instructions included with the transport packaging.

It is imperative to check the components for potential damage prior to transferring them into the building pit. The items described in these instructions apply to the separator as well as to a potential additional upstream sludge trap. For the operation and maintenance of the system, you shall receive separate instructions.

Table of Contents

1. Safety notices	1
2. Installation conditions	2
3. Assembly and Installation	8
4. Technical data	16

1. Safety notices

1. Safety notices

The applicable accident prevention regulations in accordance with the Employers' Liability Association regulations (BGV) C22 must be observed during all work. Particularly during the walk through of the tank, a second person should be present for safety reasons.

Furthermore, all relevant regulations and standards must be observed during assembly, installation, maintenance and repair. Details hereto can be found in the respective paragraphs of these instructions.



The tank cover must remain closed at all times, except for work inside the tank, otherwise there is an increased risk of accident.



The rain protection mounted at delivery only serves as packaging for the transport and is not accessible or childproof. It must be removed immediately upon delivery and replaced by an appropriate cover (telescopic dome shaft with respective cover). Only original GRAF covers or covers approved in writing by GRAF must be used.

GRAF offers a wide range of accessory parts which are precisely coordinated and can be used to complete systems. The use of accessories that have not been approved by GRAF results in the exclusion of the warranty/guarantee.

2. Installation conditions

2.1. Installation basics

- Existing drainpipes should be checked for matching connection heights.
- The materials of the inlet and outlet pipes must be resistant to wastewater light fluids containing petroleum.
- The required pipe diameter, depending on the nominal size of the separator and the required slope of the line according to the corresponding standards (EN 752-4, EN 12056-2, EN 858-1 or equivalent AS/NZS 3500.1 and AS/NZS 3500.2), must be adhered to.
- Safety against buoyancy and flotation must be ensured.
- The installation instructions for the tank must be followed.
- A sampling option should be provided.
- Proper ventilation of the inlet and outlet pipes (according to EN 1825 or equivalent AS/NZS 3500).
- The condition of all components must be checked before installation and protected from damage or dirt.
- The covers must be comply with the latest version of AS 3996. The use of interlocking or ventilating covers is not allowed.

2.2. Requirements for the installation site

- The installation site must be frost-protected.
- The installation site should be as close as possible to the wastewater accumulation location.
- The accessibility of the inlet and outlet area for cleaning vehicles and for inspection must be ensured (alignment of the shaft structures).
- The excavation base must be installed horizontally and must have sufficient base course / bearing capacity.
- The inlet and outlet lines must be installed in compliance with EN 12056 and EN 858-2 or equivalent AS/NZS 3500.1 and AS/NZS 3500.2
- Separators are to be operated without backflow by gravity. Separators with outlets below the locally specified backflow level are to be connected to the drainage system according to EN 12050 by means of sewage lifting units.
- Before filling the building pit, and possibly before connecting the inlet and outlet line, the system including shaft structure should be checked for leaks. Procedures and results of the inspection should be documented.
- Special local requirements must be taken into account (e.g. water protection area, flood prone areas etc.).

2. Installation conditions

2.2.1 Special Requirements

Water Corporation (WA):

A sampling point according to HX33-11-30 has to be installed after the oil water separator. Also a collection pit according to HX33-12-10 has to be installed prior the oil water separator. For technical details please refer to the typical drawings on Water Corporation website.

Sapphire Tank

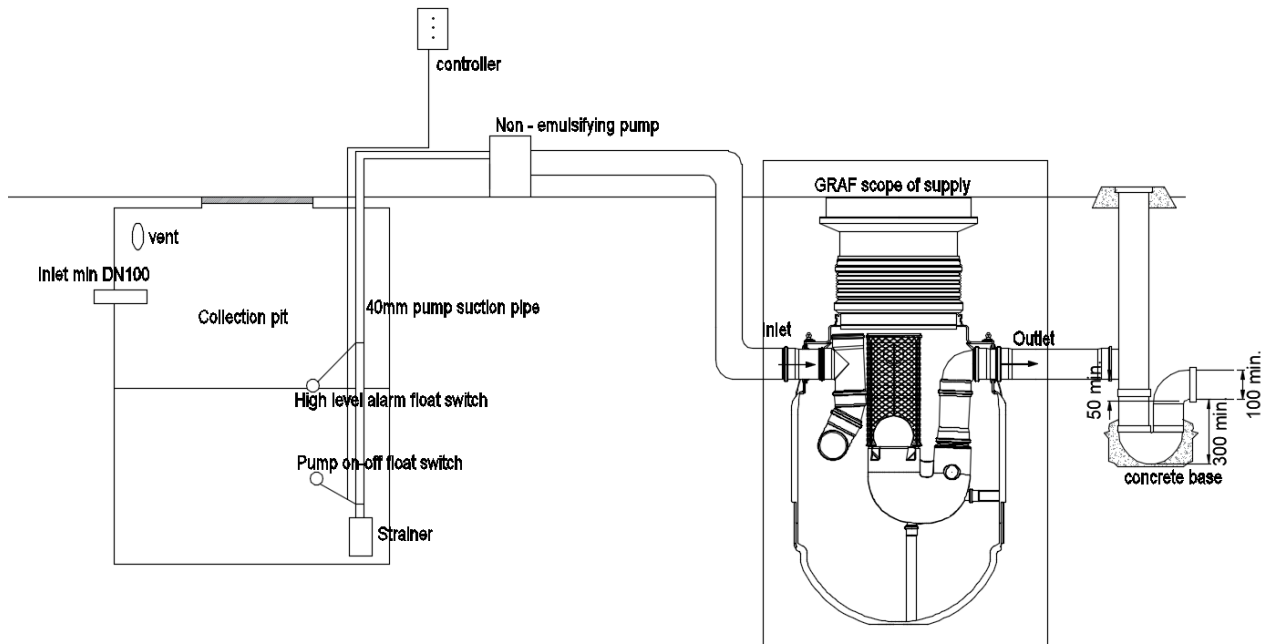

Diamant Tank

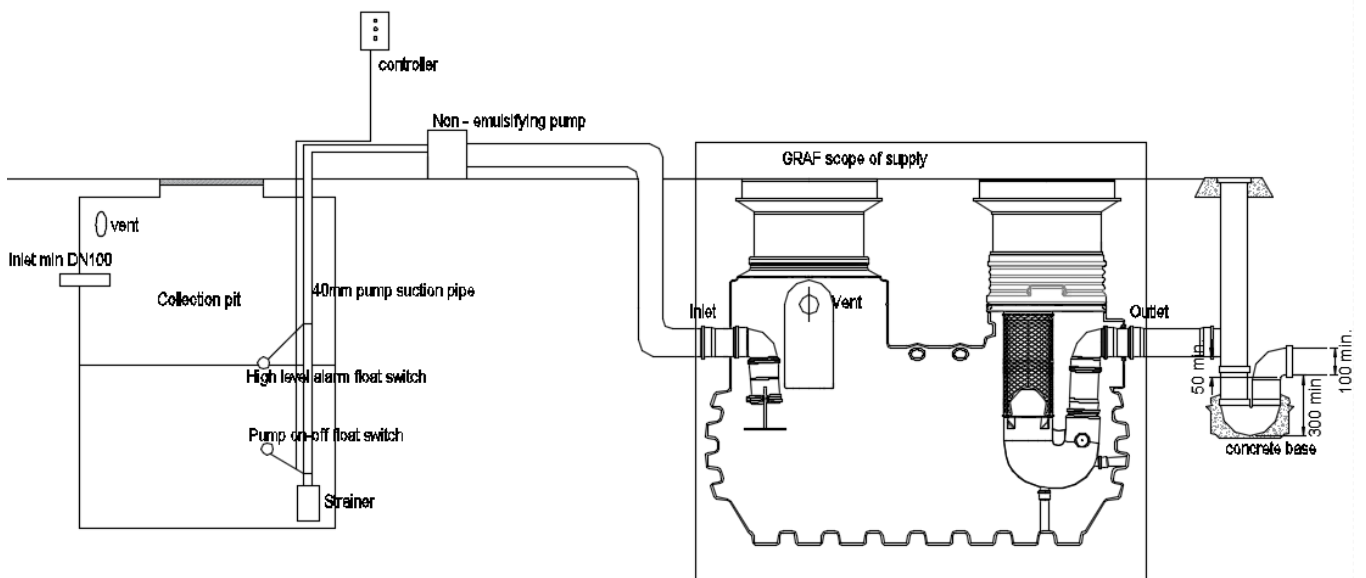

2. Installation conditions

2.3. Building site

The tank must only be installed in non-cohesive soil to slightly cohesive soil (G1 group, condition A4 and B4, degree of compaction DPR = 97 %, according to ATV-DVWK-A 127). In case of deviating installation conditions, a separate verification must be carried out.

Before installation, the following points must be clarified:

- The structural suitability of the ground.
- Maximum occurring ground water levels and infiltration capacity of the ground.

To determine the soil physical factors, a ground assessment must be carried out.

2.3.1. Ground level cover

Please take note of the maximum earth covering. This should not be exceeded.

Earth cover	Saphir	Diamant
Min	700 mm	700 mm
Max	1200 mm	1200 mm

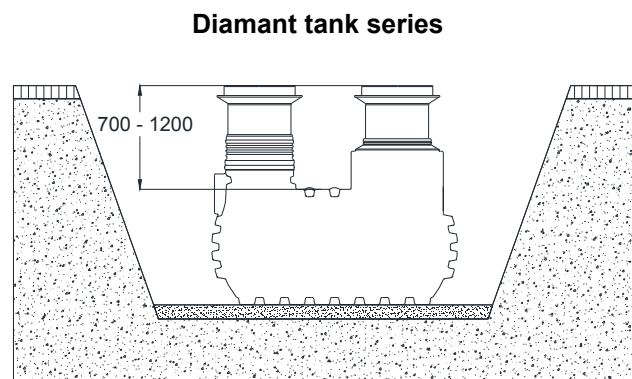
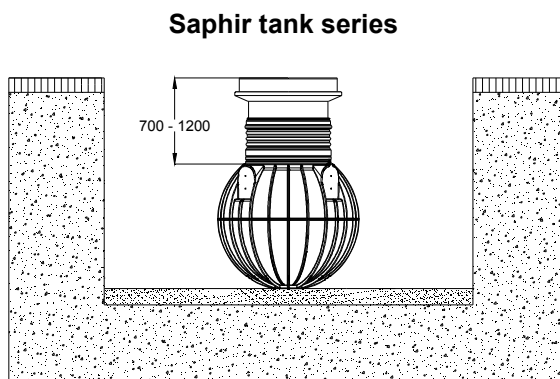

2. Installation conditions

2.3.2. Slope, embankment, etc.

During the installation of the tank in close proximity (<5 m) to a slope, mound or embankment (greater than 5°), a statically calculated retaining wall must be built to absorb the active earth pressure. The wall must exceed the tank dimensions by at least 500 mm and must have a minimum clearance of 1000 mm to the tank.

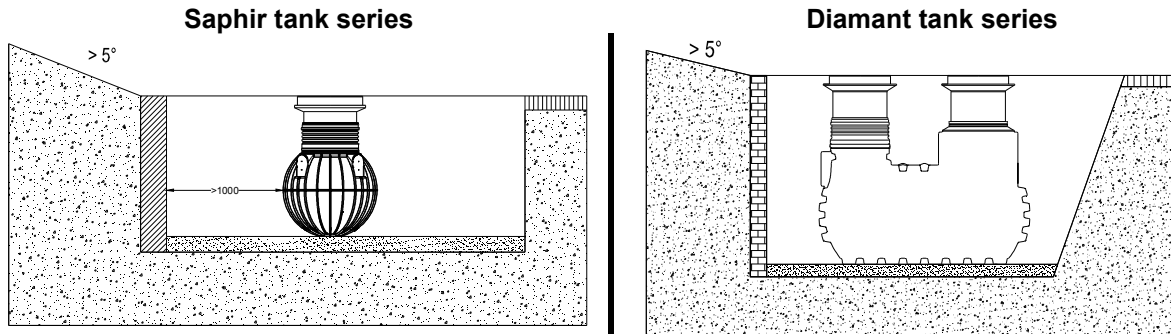

2.3.3. Ground water and cohesive (water-impermeable) soil (e.g. clay soil)

The tank must only be installed into groundwater/stratum water up to the levels specified in the following table. If it is to be expected that groundwater/stratum water levels - even if only occasionally - exceed these levels, it must be drained.

The drainage line may end up in a vertically installed DN 300 pipe, equipped with a submersible pressure pump that drains the excess water. The pump must be inspected in regular intervals.

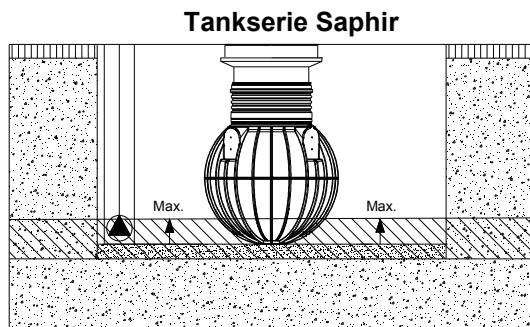

Typ	max. groundwater level [mm]
NS3-300	430
NS3-400T, NS3-600, NS6-600,	550

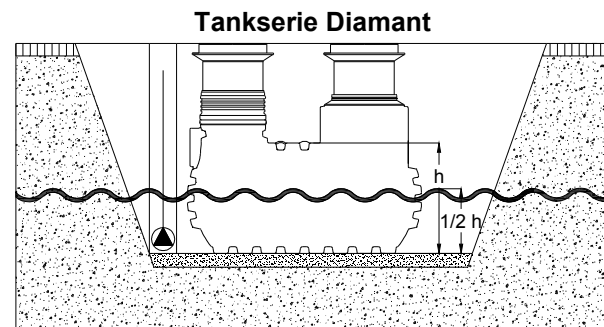

Typ	max. groundwater level [mm]
NS 6-1300, NS 10-1300	575 (1/2 h)
NS 10-4000, NS 15-2000	700 (1/2 h)

2. Installation conditions

2.3.4. Bank

The separator must be installed in a way so that the upper edge of the covers is aligned adequately high with the standard level of the area to be drained. The required banks can be taken from the table mentioned below.

Typ	Bank
KLsepa.compact	[cm]
NS3-300	16
NS3-400T,	19
NS3-600, NS6-600	15
NS6-1300, NS10-1300	12
NS10-2000, NS15-2000	15

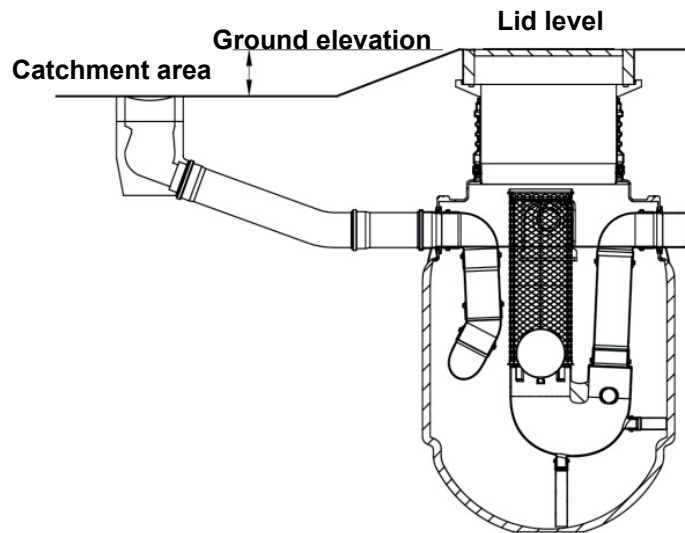

2.3.5. Accessible cover class A (AS 3996)

If there is no car traffic over the tank area and no load distribution plate is installed, the clearance to the passable areas must correspond with the building pit depth.

Saphir tank series

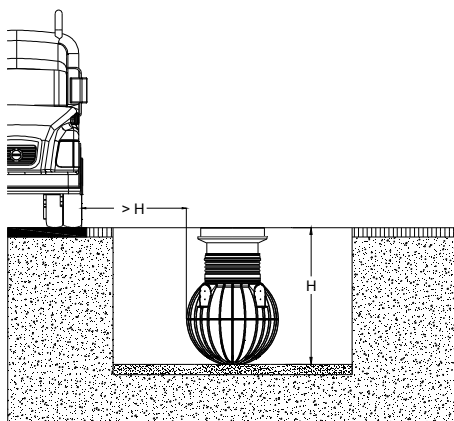

Diamant tank series

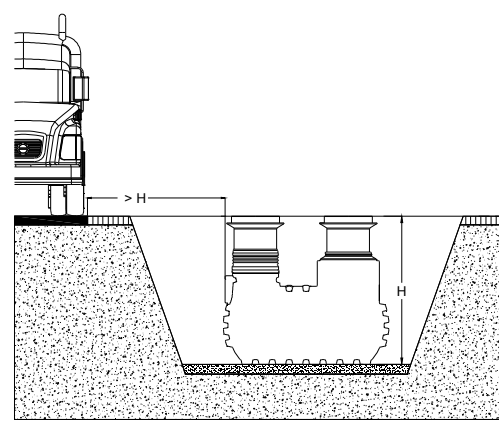

2. Installation conditions

2.3.6. Cover suitable for car traffic class B (AS 3996)

In case of car traffic, an appropriate cover according to AS3996 class B must be used. In addition, the telescopes must be equipped with a concrete collar. In reference to this, please see section 3.3.2.

Saphir tank series

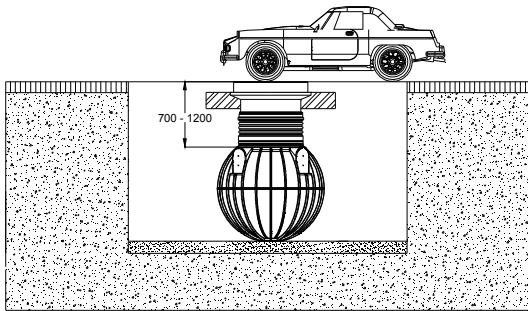

Diamant tank series

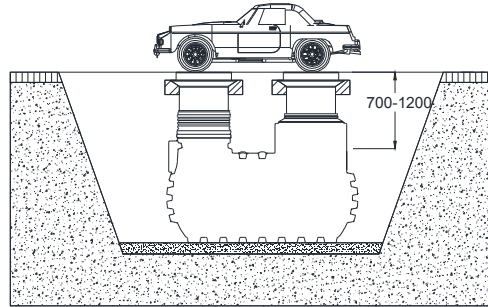

2.3.7. Cover suitable for truck/heavy load traffic class D (AS 3996)

In case of heavy truck traffic, an appropriate cover according to AS3996 class D must be used. In addition a load distribution plate must be provided on site (structural drawing available at GRAF GmbH).

Saphir tank series

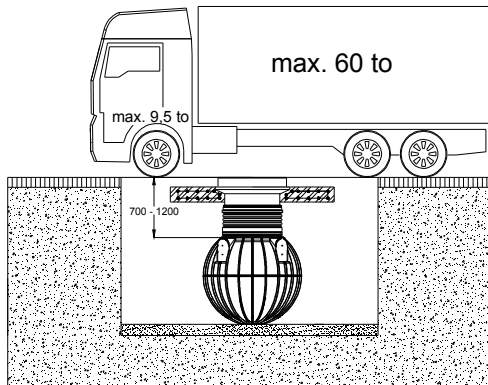

Diamant tank series

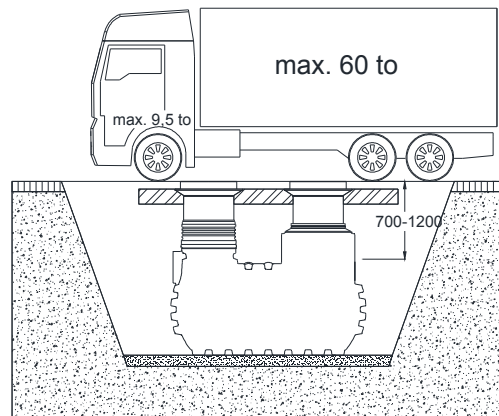

3. Assembly and Installation

3. Assembly and Installation

3.1. Building pit

In order to leave adequate work space, the ground surface of the building pit must exceed the tank dimensions by > 500 mm on each side. The clearance to fixed structures must be at least 1000 mm.

A slope with the angle β must be applied according to the following table.

Soil typ	Slope angle β in °
Non-cohesive or soft, cohesive soil	$\leq 45^\circ$
→ Tank must be suitable for car traffic (cover B125, D400)	$\leq 50^\circ$
Stiff or semi-firm, cohesive soil (tank accessible only)	$\leq 60^\circ$
Rock (tank accessible only)	$\leq 80^\circ$

Attention: In order to be suitable for car traffic, a slope angle of a maximum of 50° must be adhered to. The building site must be horizontal and even and must provide adequate load-bearing capacity.

The depth of the trench must be designed so the maximum earth covering from the shoulder of the tank does not exceed 1200mm.

A layer of compact grounded gravel (maximum grain size 8/16 mm, thickness at least 150 mm) must be laid down as a substructure.

3. Assembly and Installation

3.2. Final installation

3.2.1. Positioning of the tank

The tank must be placed shock-proof and with adequate equipment into the prepared building pit. After placing the tank, it must be positioned in the pit in such a way that the inlet is aligned along the axis of the inlet line. The tank should be positioned vertically. After positioning the tank, fill the excavation layer by layer according to section 3.2.2.

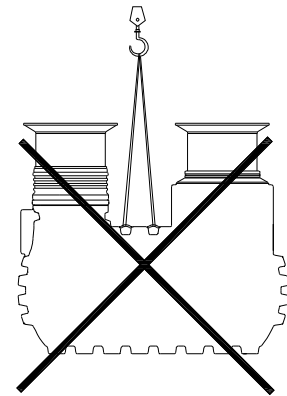

3.2.2. Backfill

In order to avoid deformations of the tanks, the filling of the tank and the filling of the building pit should be carried out simultaneously. Before filling the tank, the outlet bend is filled with water (otherwise it might float and damage the assembly components!), then the tank will be filled up to 1/3; then the excavation is filled with layers of a maximum of 30 cm (grounded gravels with a maximum grain size of 8/16) up to the tank's upper edge. The individual layers must be compacted well (manual compactor). In order to prevent damage to the tank, the use of mechanical compacting equipment is not permitted at any time. The excavation must be at least 500 mm wide.

Attention: In order to be suitable for truck traffic (SLW40), a geotextile must be horizontally installed around the clearance areas!

IMPORTANT:
First fill up the outlet bend!

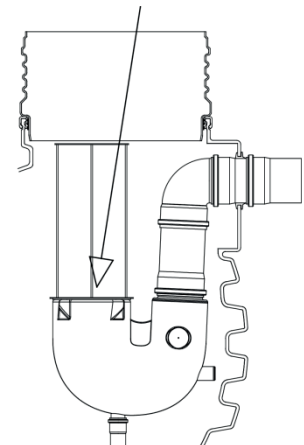

Saphir tank series

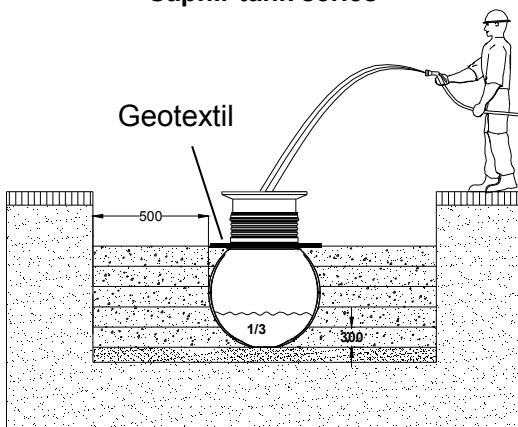

Dimensions geotextile
1150 x 1150 mm

Diamant tank series

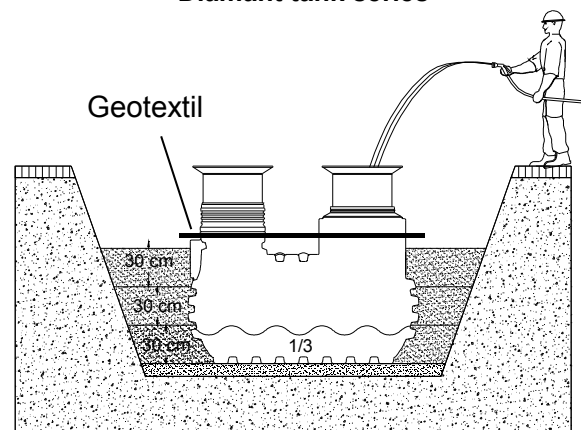

Dimensions geotextile
NS6-1300, NS 10-1300: 1150 x 1150 mm
NS10-4000, NS 15-4000: 1400 x 2450 mm

3. Assembly and Installation

3.2.3. Connection of inlet and outlet

When the excavation is backfilled to the lower edge of the inlet and outlet connections and compacted, the inlet and outlet lines are laid frost-protected and are connected.

After connecting the inlet and outlet lines, check whether the assembly components are in a vertical position. If they are not, position them according to the following figure.

Notes regarding the warning system:
During the ground work, lay out the connection cables or empty pipes.

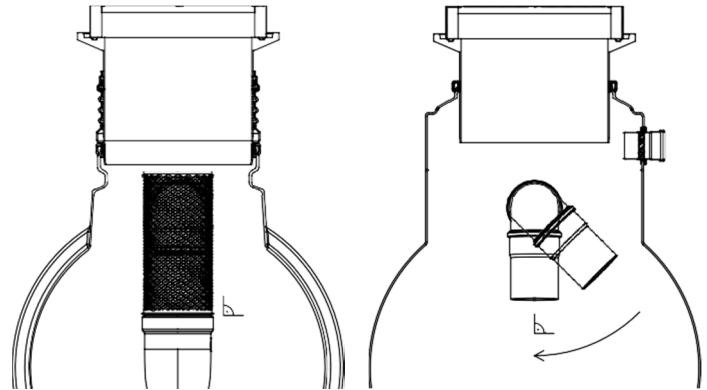

3.2.4. Connecting the sampling shaft

The sampling shaft must be positioned in flow direction immediately after the separator. For the installation, the installation instructions with regard to the “Sampling shaft” must be followed.

3.2.5. Connecting the warning system pipe

For the installation of a warning system, a borehole must be placed in the separator on the side that faces the installation site of the warning equipment. The opening should be placed as high as possible above the at-rest water level in the system.

The connecting line between the separator and the control unit must remain as short as possible. Unnecessary changes of direction, in particular such with an angle more than 45° must be avoided. The empty cable conduit must have a continuous downward slope towards the separator.

Formation of condensation inside the cable conduits can be minimised by an air-tight closure of the empty pipe on the side of the control unit. For potential subsequent wiring work, a pull wire should be added.

3. Assembly and Installation

3.2.6. Tank installation

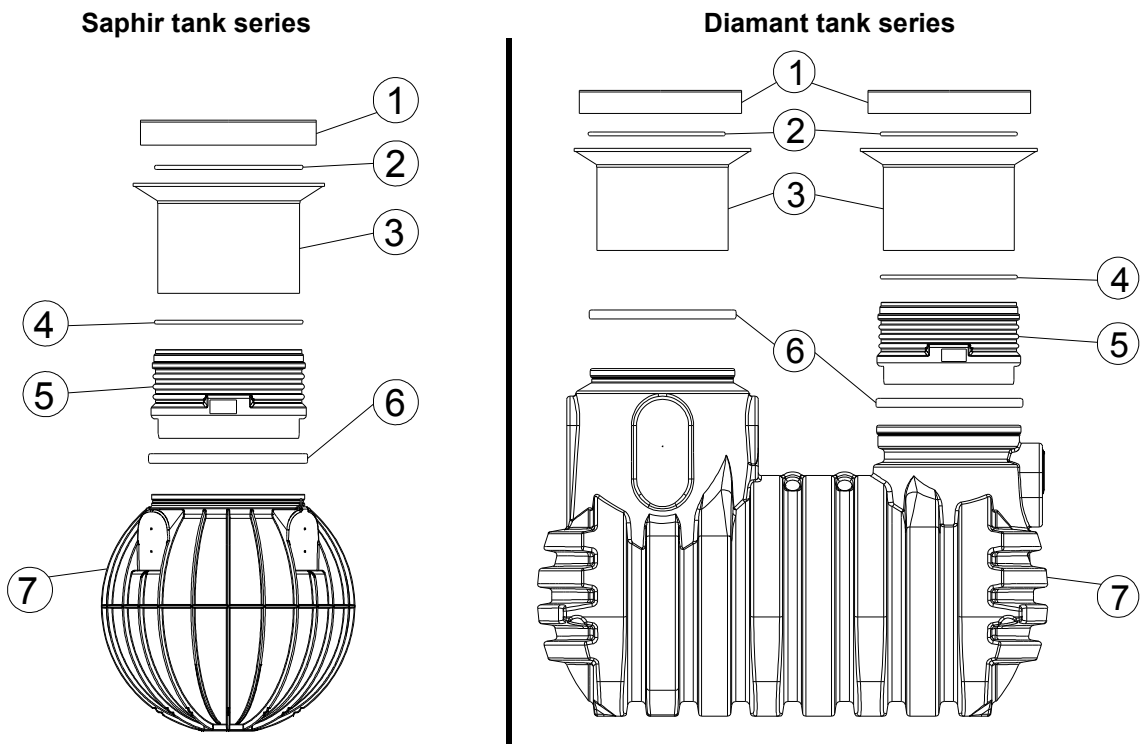

* Up to two adaptors with respective seals can be installed.

- ① Concrete cover
- ② NBR seal
- ③ Telescope
- ④ Gasket for adaptor
- ⑤ Adaptor*
- ⑥ Profile gasket
- ⑦ Separator tank

3.2.7. Installation of adaptors and the telescopic dome shaft

The profile gasket ⑥ must be mounted onto the tank opening and the adaptor ⑤ inserted as far as the stop. Before inserting the adaptor, the seal must be lubricated with soft soap.

The seal ④ is mounted into the adaptor and the telescopic dome shaft ③ is inserted

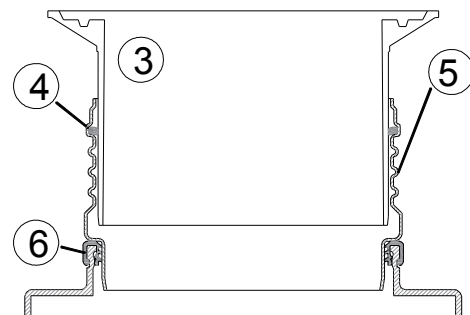

3. Assembly and Installation

3.2.8. Installation of telescopic dome shaft directly onto the tank

In order to install the telescopic dome shaft onto the tank, the profile gasket ⑥ is mounted onto the tank opening and the telescopic dome shaft is inserted.

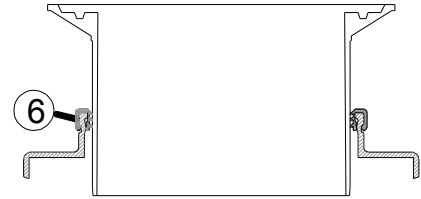

3.3. Installation of the shaft structers

Instructions regarding the covers: The covers used for light fluid separators must meet the provisions of AS 3996. The cover(s) must not be equipped with openings to vent. It's not allowed to fastened with screws.

3.3.1. Accessible

In order to prevent transferring loads onto the tank, the telescope is filled with layers of grounded gravels (maximum grain size 8/16) and compacted evenly. Subsequently an Ottocoll M500 cord is inserted into the groove of the telescopic dome shaft ③, then insert the hose seal ②. On top of the hose seal a cord of Ottocoll M500 also needs to be applied. Finally, the cover ① is placed onto the telescopic dome shaft.

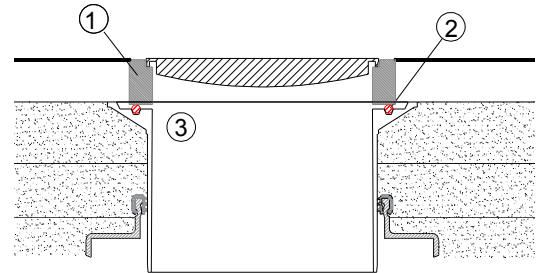

3. Assembly and Installation

3.3.2. Suitable car traffic (class B)

If the tank is installed underneath an area with car traffic, a concrete ring (property class N25) must be placed in the collar area under the telescopic dome shaft for trucks. The circumference of the concrete layer to be filled in must be at least 300 mm wide and approx. 200 mm high. Subsequently an Ottocoll M500 cord is inserted into the groove of the telescopic dome shaft ③, then insert the hose seal ②. On top of the hose seal a cord of Ottocoll M500 also needs to be applied. At last, the cover ① is placed onto the telescopic dome shaft.

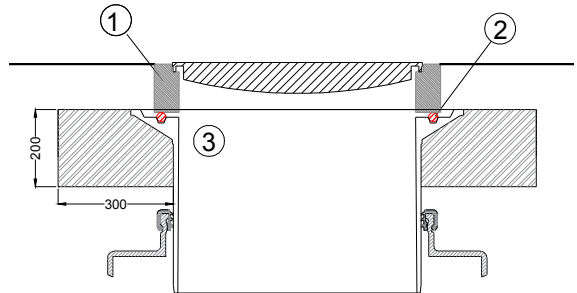

Note! The area is trafficable once the concrete is cured.

3.3.3. Suitable for heavy load traffic (SLW40, cover D400)

A load distribution plate (property class N40) must be installed under the telescope for installations in areas with heavy load traffic. A respective formwork and reinforcement plan is available from the manufacturer. An adequately compacted, anti-capillary and draining base course must be installed underneath the load distribution plate. A geotextile must be laid horizontally at the level of the tank opening. Subsequently an Ottocoll M500 cord is inserted into the groove of the telescopic dome shaft ③, then insert the hose seal ②. On top of the hose seal a cord of Ottocoll M500 also needs to be applied. At last, the cover ① is placed onto the telescopic dome shaft.

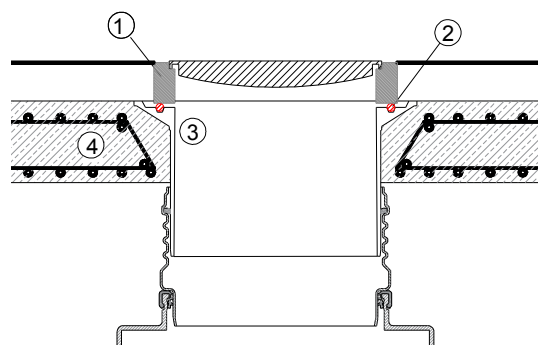

3. Assembly and Installation

3.4. Warning system

The sensors of the warning system must - depending on the capacity of the separator - be installed on various height levels. The installation measurements are shown in the pictured table.

Warning system type	Oil	High level	Sludge
Clearance	a [mm]	b [mm]	c [mm]
NS3-300	740	1200	460
NS3-400T,	920	1550	560
NS3-600, NS6-600	1070	1500	730
NS6-1300, NS10-1300	870	1350	610
NS10-2000, NS15-2000	1050	1600	740

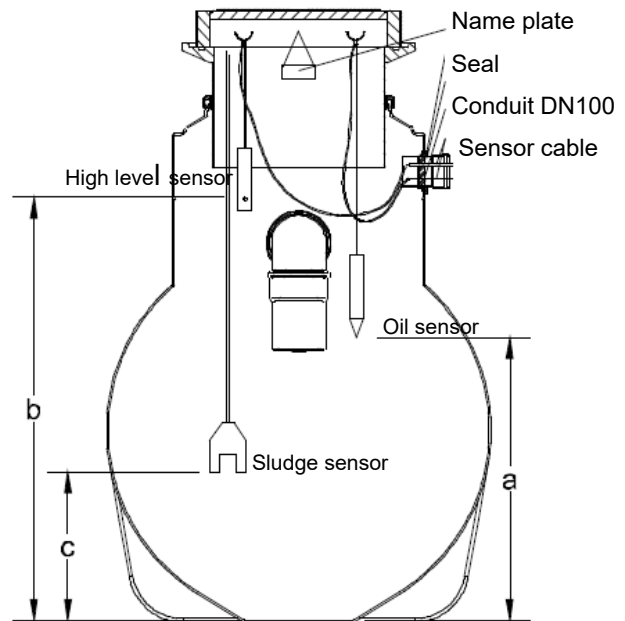

For the installation and maintenance of the warning system please refer to the attached original operating manual.

Attention: The holes for the mounting set must only be placed at the indicated positions in the concrete frame. On no account must the separator be damaged or perforated! For the process of pulling the cables through the empty pipes to the control unit the wall duct must already be tightened firmly.

3. Assembly and Installation

3.5. Commissioning

- If there is not already one in place, the nameplate delivered with every separator must be attached via a chain to the shaft just underneath the cover.
- To commission the separator, fill it with grease-free and oil-free water until the water begins to flow out of the discharge pipe. If a mixture of oil and water is fed into an empty tank, the separator system will not work properly and the wastewater would leave the separator system in a state that is cleaned insufficiently.
- When the separator is filled, the float must now be inserted into the guide rails of the outlet. Check, whether the float can be moved freely upward and downward. For class I separators the coalescence unit must now be inserted into the guide rails until it sits on the outlet bend.
- All relevant information, including the serial number from the identification plate must be entered into this operating manual!
- Commissioning must be documented in the commissioning report. Any claims under the warranty can only be made if the completed commissioning report is provided!

4. Technical data

4. Technical data

4.1. Saphir tank series

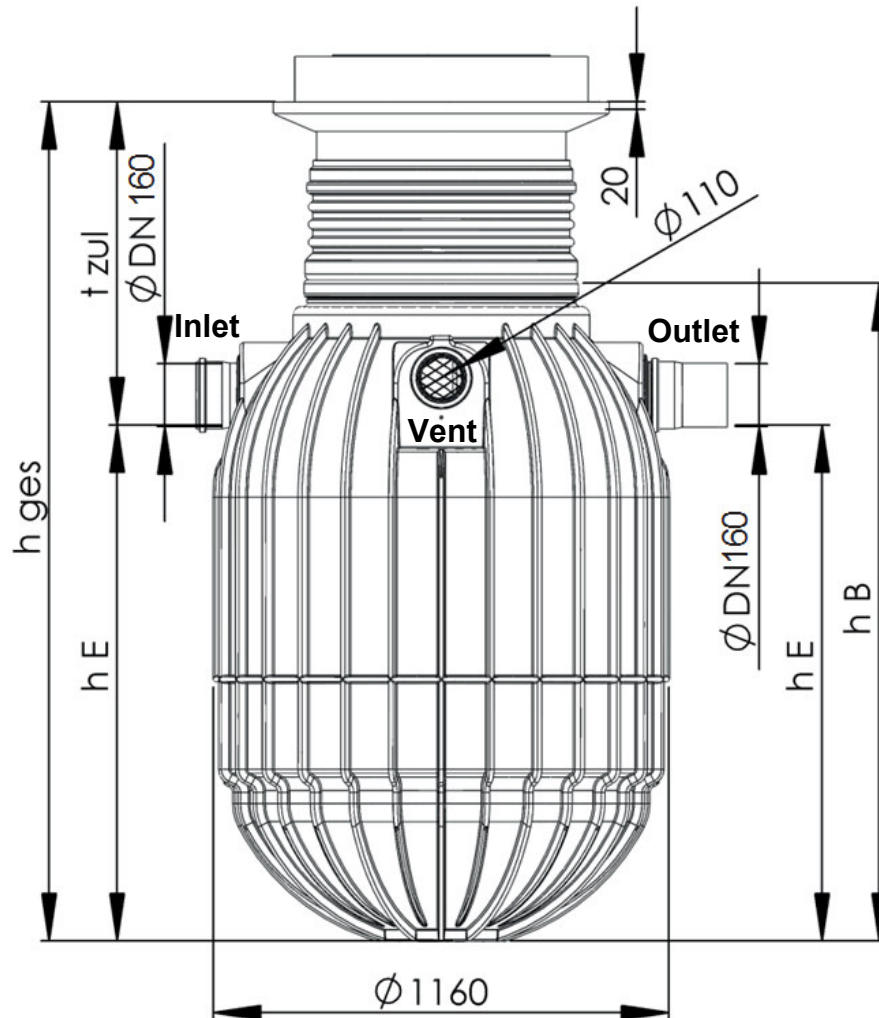

KLsepa.compact		NS 3-300	NS 3-400-3, NS 3-600 NS 6-600
Heights	h_E [mm]	995	1320
	t_{zul} [mm]	810 - 1010	810 - 1010
	h_{ges} [mm]	1805 - 2005	2130 - 2330
	h_B [mm]	1345	1670
Connections	DN	160	160
Weight	[kg]	80	110

4. Technical data

4.2. Diamant tank series

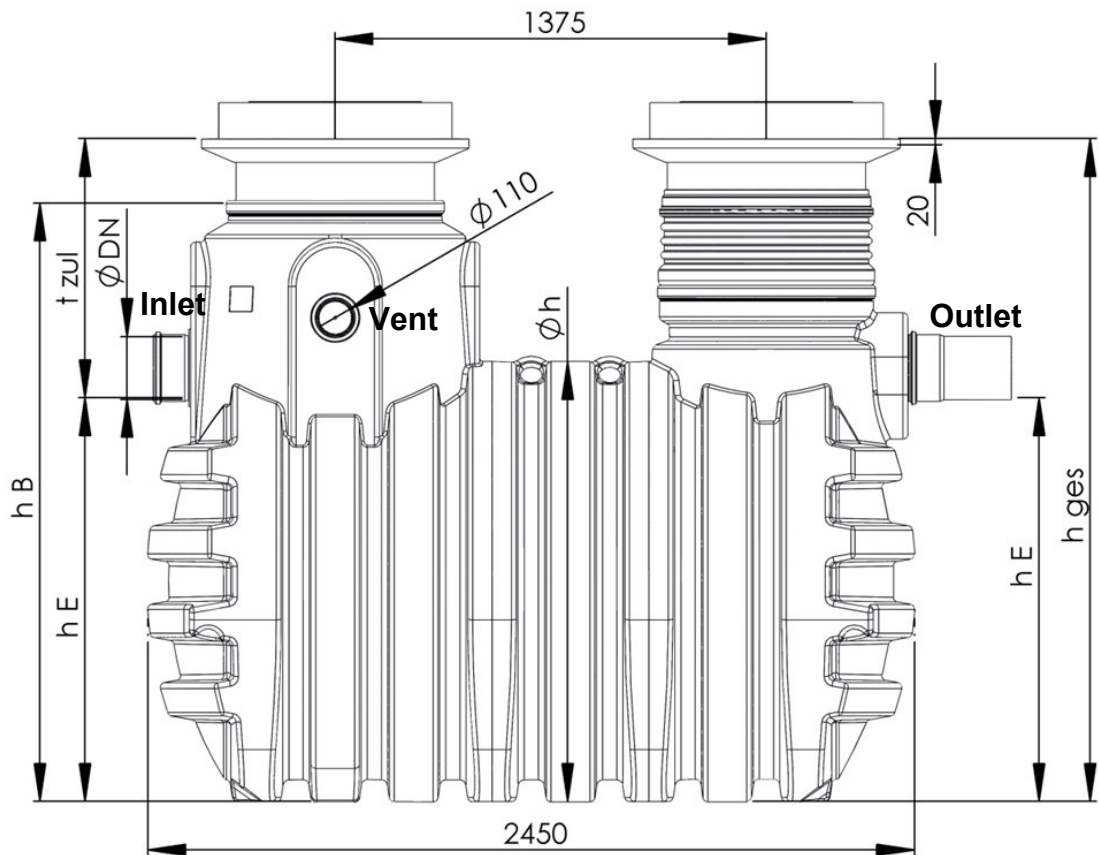

KLsepa.compact		NS 6-1300 NS 10-1300	NS 10-4000 NS 15-4000
Heights	h_E [mm]	1085	1280
	t_{zul} [mm]	775 – 975	830 – 1030
	h_{ges} [mm]	1860 – 2060	2110 – 2310
	h [mm]	1150	1400
	h_B [mm]	1655	1905
Connections	DN	160	200
Weight	[kg]	165	250

4. Technical data

4.3. Sludge Traps (optional)

4.3.1. Saphir tank series

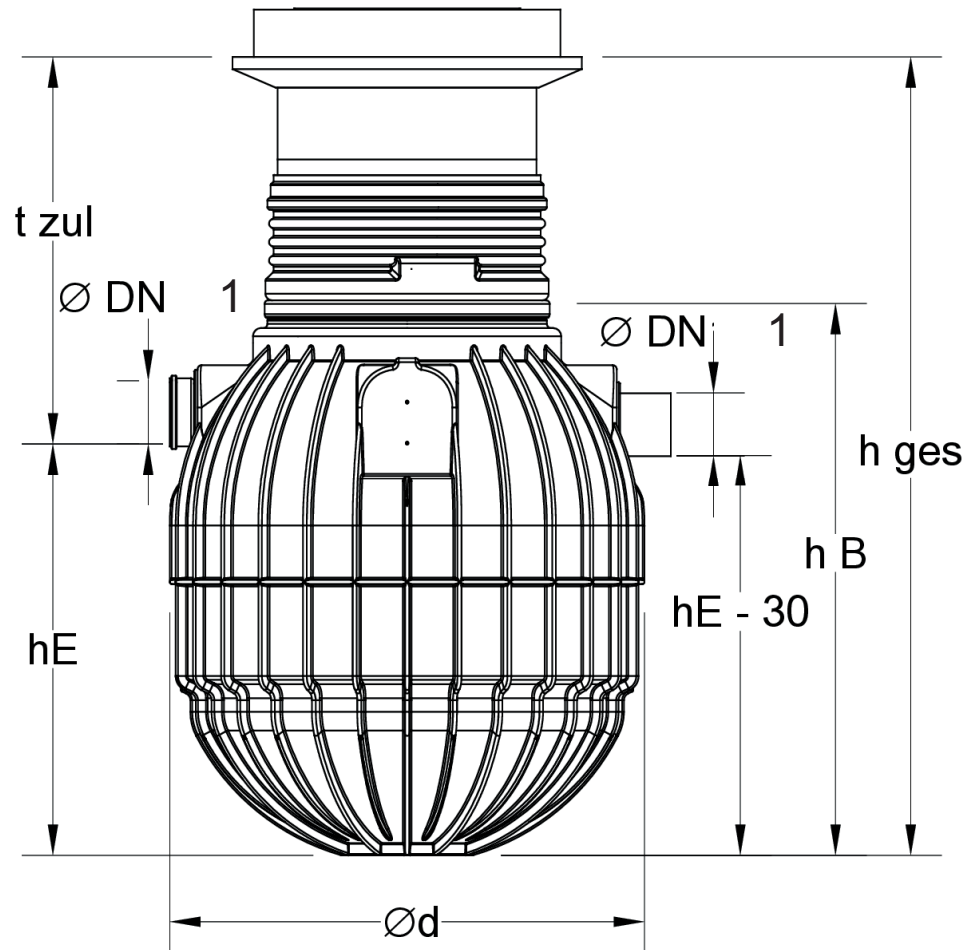

Sludge trap		1000 L
Heights	h_E [mm]	1320
	t_{zul} [mm]	810 - 1010
	h_{ges} [mm]	2130 - 2330
	h_B [mm]	1670
Connections	DN	160
Weight	[kg]	95

4. Technical data

4.3.2. Diamant tank series

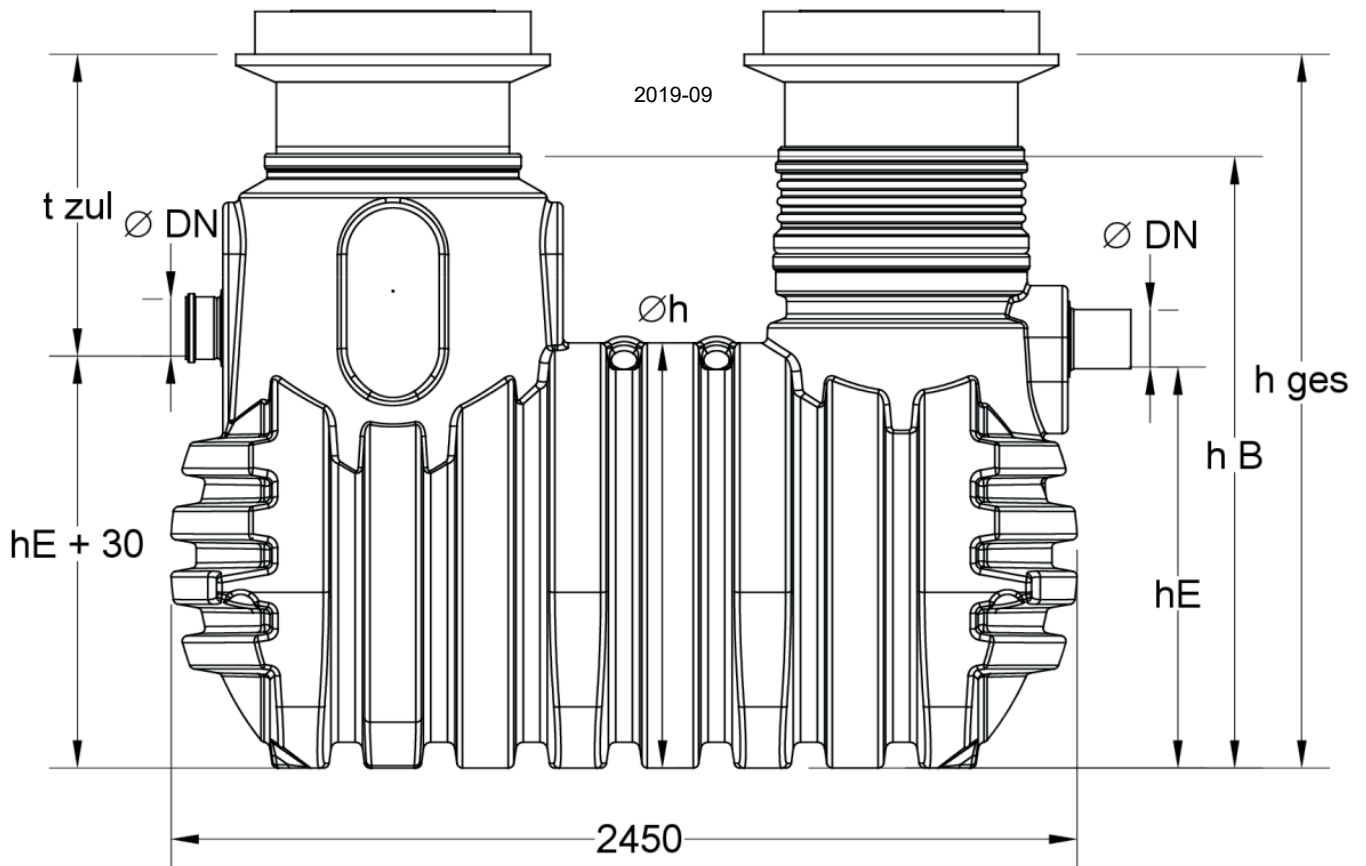

Sludge trap		2100 L		3200 L		4600 L	
Connections	DN	160	200	160	200	160	200
Heights	h_E [mm]	1085	1060	1305	1280		
	t_{zul} [mm]	745 - 945	770 - 970	775 - 975	800 - 1000	755 - 955	780 - 980
	h_{ges} [mm]	1860 - 2060	1860 - 2060	2110 - 2310	2110 - 2310	2410 - 2610	2410 - 2610
	h [mm]	1150	1150	1400	1400	1700	1700
	h_B [mm]	1655	1655	1905	1905	2200	2200
Weight	kg	155	155	240	240	250	250

4. Technical data

4.4. Sampling shaft DN600

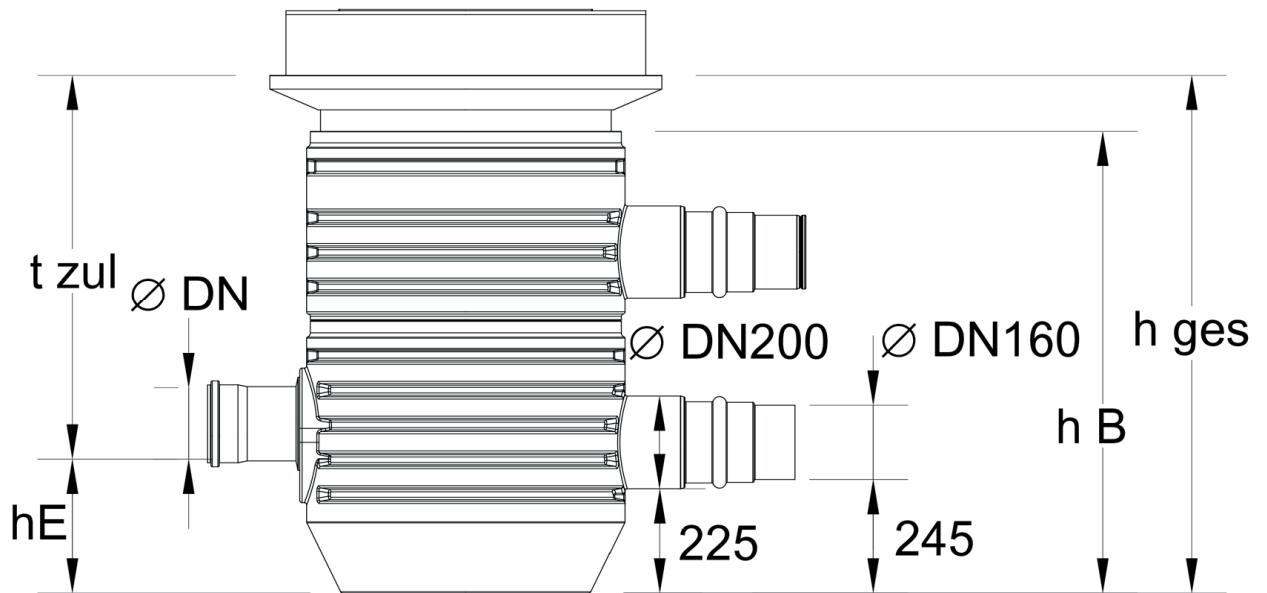

Sampling shaft		DN 160	DN 200
Connections	DN	160	200
Heights	h_E [mm]	280	260
	h_{zul} [mm]	860 - 1060	880 - 1080
	h_{ges} [mm]	1140 - 1340	1140 - 1340
	h_B [mm]	1000	1000
	Weight	[kg]	19



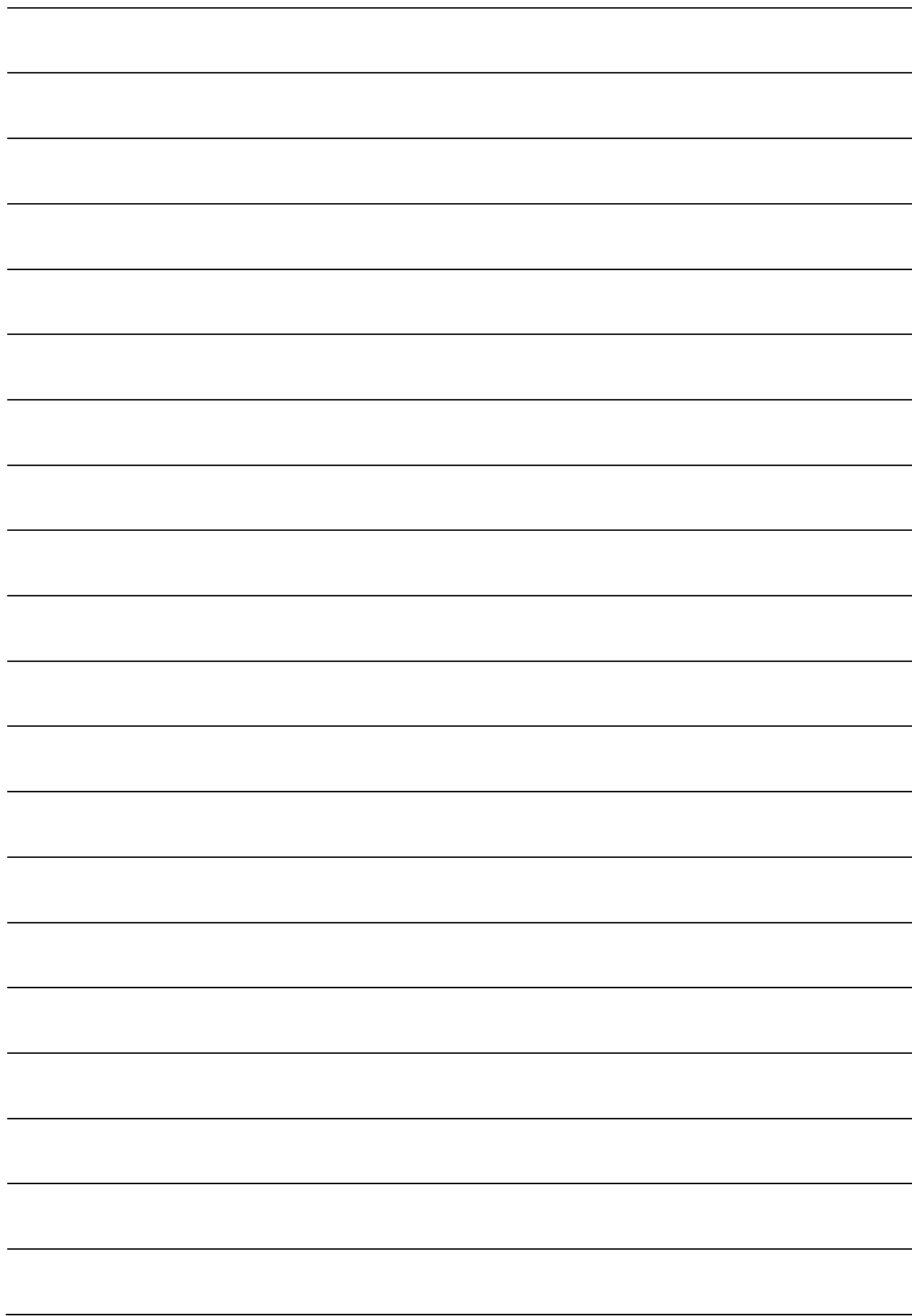

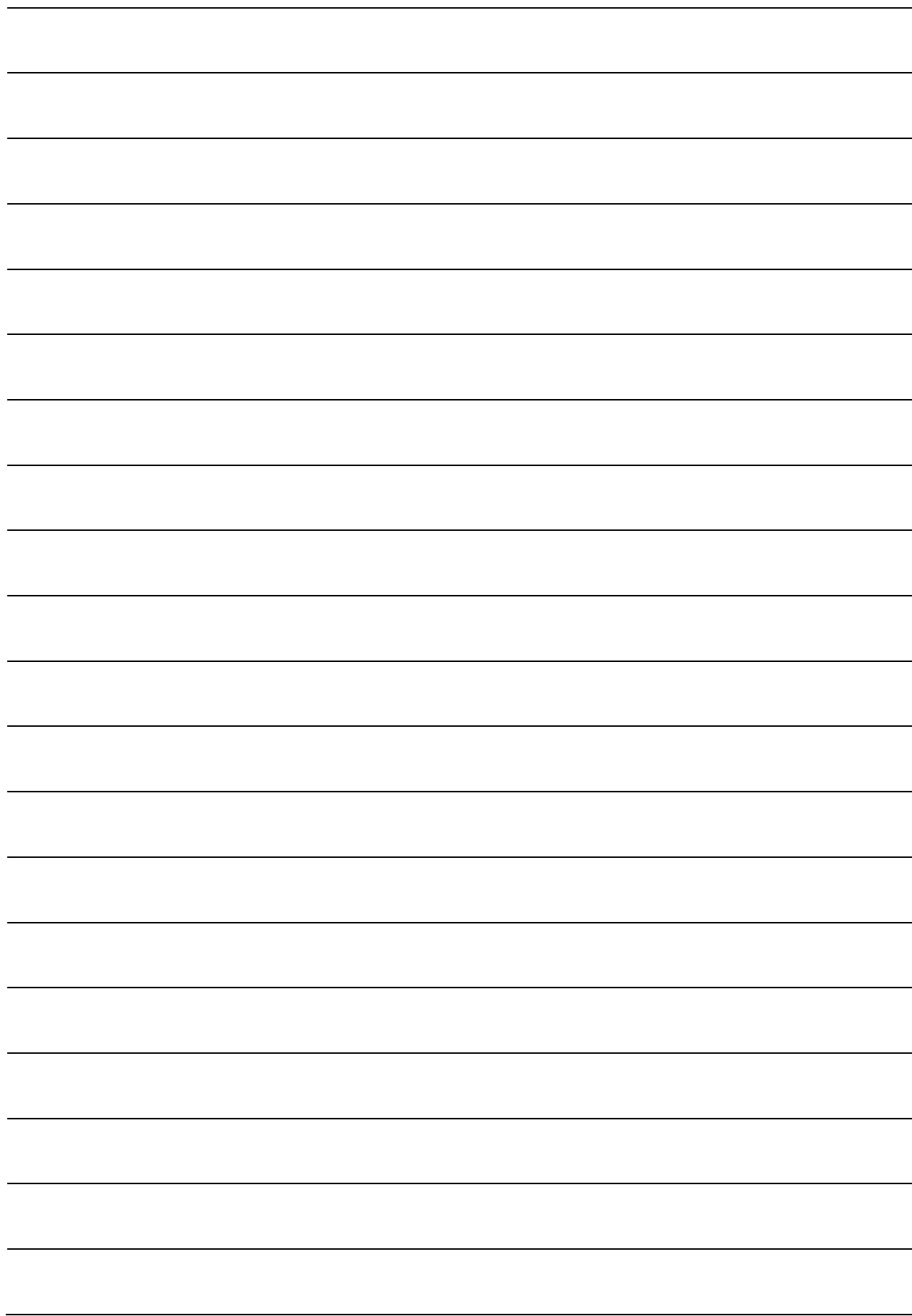

Operating and Maintenance Manual for Oil Water Separator Systems KLsepa.compact

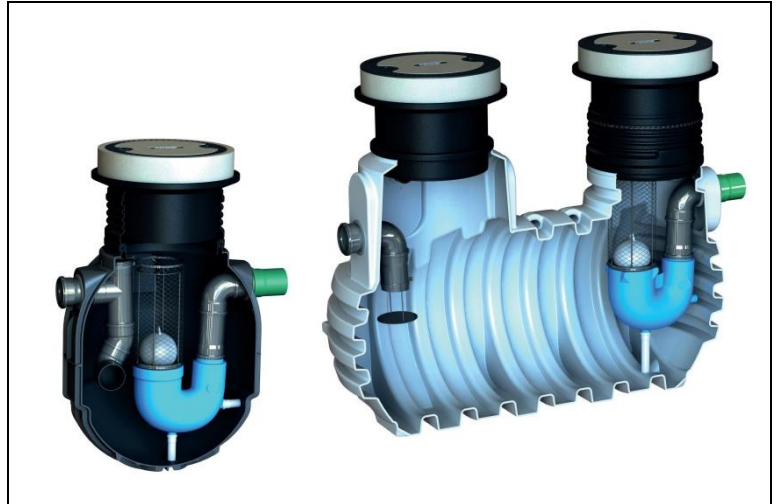
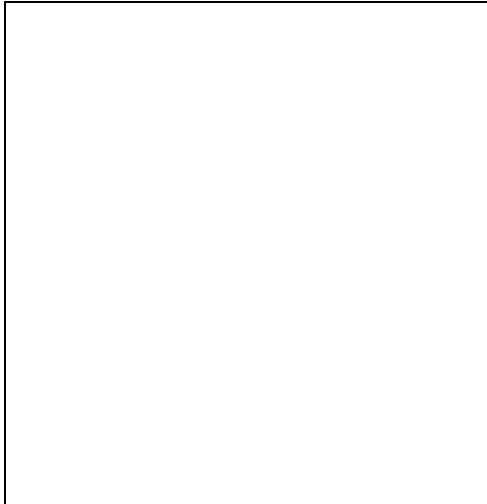

It is imperative to observe the items described in this operating manual. In case of non-compliance, all warranty claims shall lapse.

Missing instructions must be requested from us without delay.

It is imperative to check the tanks for potential damage prior to transferring them into the building pit!

The installation must be carried out by a specialised company.

Contents

1. General safety instructions	1
2. Initial commissioning / water tightness test	4
3. Operation and maintenance according to EN 858-2	5
4. Record of commissioning	9

System

System

Compact separator

Coalescence (Class. I)

Petrol (Class. II)

Nominal size NS: _____

Sampling point:

Internal

External

Article number: _____

Order confirmation no.

A- _____

Sludge trap: _____

Liter

Oil volume: _____

Liter

Alert system?

Signalling oil layer thickness

Signalling backwater

Name of the person responsible for the technical operation: _____

Name of the responsible operating staff member on duty: _____

Commissioned on: _____

Has a disposal contract been signed with an authorised specialist company?

YES

NO

Name: _____

Address: _____

1. General safety instructions

1. General safety instructions

This section contains information on safety measures and residual risks. Read this chapter carefully before using the system to ensure safety in handling of the system.

The applicable accident prevention regulations must be observed during all work. Particularly during the walk through of the tanks, a second person should be present for safety reasons.

Furthermore, all relevant regulations and standards must be observed during assembly, installation, maintenance and repair. Details hereto can be found in the respective paragraphs of this operating manual.

The installation of the system and individual components must be carried out by a specialised company. The overall system must be shut down during all work on the system or the components.

The tank cover must remain closed at all times, except for work inside the tank, otherwise there is a risk of accident. The rain protection mounted at delivery only serves as packaging for the transport and is not accessible or childproof. It must be removed immediately upon delivery and replaced by an appropriate cover (telescopic dome shaft with respective cover).

Only covers that comply with EN124 (or equivalent AS3996) must be used.

1.1. Marking obligation

All covers of the separator system must be marked accordingly with the class of the cover according to EN 124 or equivalent AS3996. Furthermore, the provided identification plate must be attached in a clearly visible manner at one of the access shafts.

1.2. Explanation of Warnings and Prohibitions



Hazard warning



Warning of dangerous electrical voltage



Warning of danger of falling



Warning of hand injuries



Warning of explosive atmospheres



Prohibition of fire, open flames, and smoking

1. General safety instructions

1.3. Hazard statements

1. To ensure safety, all persons coming into direct contact with the plant must take note of the contents of this documentation.
2. It is prohibited to use the system for a purpose other than that described by the manufacturer.
3. Locally applicable labour and safety regulations and laws must be followed even if they are not explicitly listed in this guide. The same applies to environmental legislation.
4. If the operator detects faults or dangers, the manufacturer or the responsible maintenance company must be informed immediately.
5. Safety devices must never be removed or bypassed during normal operation. Safety devices may be temporarily bridged or disabled only by maintenance staff during repair and maintenance.
6. If the use of personal protective equipment (safety shoes, safety glasses, gloves, ear protection, etc.) is required, it must be ensured that it will be used. Defective or damaged personal protective equipment must be replaced immediately with properly functional protection.
7. Work on electrical installations may only be performed by qualified personnel.
8. All safety instructions and warnings on the machine must be kept in easily legible condition.
9. Hot parts must not come into contact with explosive or flammable chemicals.
10. The plant must not be operated under the influence of alcohol (be careful about any residual alcohol from the previous day!) or of medication affecting perception and responsiveness.

1. General safety instructions

1.4. Warnings

Always observe these instructions as personal injury or property damage may result otherwise!



Make sure that the warning system is not installed above or in the immediate vicinity of water vessels. Risk of electric shock in case of improper installation.

Installation site



Electrical supply circuit

Always connect the warning system to a properly installed 230 V socket or grounded socket that is protected with a 16A fuse in accordance with the technical specifications.

In the event of a thunderstorm, electrical equipment connected to the mains may be damaged. An overvoltage protection device in the building installation is recommended as protection. The connection lines must be laid in a manner that they do not present a tripping hazard.



Explosive Atmospheres

The warning system must not be installed or switched on in environments with a potentially explosive atmosphere or in places where combustible materials are present. Sparks in such environments could cause explosion or fire, which can lead to injury or death..



Damages

The warning system must not be operated if the housing or the insulation of a line is damaged or dented.



Service work

Servicing of the system must be carried out by authorised, qualified personnel or qualified electricians.



Power supply

The power supply must be guaranteed at all times. Please make sure of that. Additional power consumers on the same fuse may disrupt operation.

2. Initial commissioning / water tightness test

2. Initial commissioning / water tightness test

Prior to the first commissioning, the system must be filled with clean water until no further rise of the water level is noticeable. For this purpose, the float must be lifted or removed, as it will otherwise be sucked down and not be able to rise to the surface on its own.

After filling the system up with fresh water, the float is inserted into the float guide. The float will stick out approx. 2 to 3 cm above the water surface and must be able to freely float.

If a mixture of oil and water is fed into an empty tank, the separator system will not work properly and the wastewater would leave the separator system in a state that is cleaned insufficiently.

The identification plates with chain provided for each separator system must be attached underneath the concrete cover to the lower edge of the dome.

The taper shaft ring must be covered by the original cover supplied and must be marked "separator system".

All relevant information, including the serial number from the type approval plate must be entered on page 2 in this operating manual!

Commissioning must be documented in the commissioning report (please refer to section 4 in the annex). Any claims under the warranty can only be made if the completed commissioning report is provided!

3. Operation and maintenance according to EN 858-2

3. Operation and maintenance according to EN 858-2

3.1. Operation

In general, the provisions of EN 858-2 apply. Please note the following issues:

- The draining intervals must be arranged such that a continuous and flawless functioning of the system is ensured. The drainage must be carried out at least semi-annually (for exceptions see next point).
- Maintenance must be carried out according to the maintenance instructions for the sepa.compact separator system. After conclusion of a maintenance contract the maintenance company shall carry out this kind of work. This is the only way to guarantee steady functionality.
- The operator must make sure that no unauthorised substances or stable emulsions are introduced into the separator. It is essential to make sure that only harmless washing and cleaning agents are used for the separator system. Do not use cleaning agents containing solvents. It is advised to have the manufacturer of the cleaning agent confirm that.
- Only the amount of wastewater determined by the dimensions may be fed into the separator system. It may only contain light liquids comprising free (floating) mineral oils. Emulsions and the share of dissolved oils such as during the use of washing and cleaning agents that are hard to separate for the cleaning of the motor and chassis cannot be retained (please refer to the table of substances in the technical specification).
- Unauthorised removal of separator components such as the float, is not permitted.
- Prior to accessing the container, it must be vented appropriately. Smoking is not allowed at all times. It is advised to additionally use respiratory protective devices.

3. Operation and maintenance according to EN 858-2

3.2. Maintenance

All measurements and events must be recorded in the operational log!

The extension of disposal intervals must be communicated to the relevant authority, if required according to the applicable wastewater regulations.

3.2.1. Monthly self-inspection by the operator

1. Measure the oil layer thickness
2. Determine the height of the sludge level
3. Visually inspect the coalescence unit and clean or replace, if necessary
4. Check for a potential difference in water level before and after the coalescence level
5. Check automatic closure device for ease of movement and cleanliness; press the float down about 2 cm and check whether it rises by itself; clean, if necessary.
6. Skim off floating substances.
7. Monitor formation of odours (thinners, waxes, etc.)
8. Check the warning and/or control system for cleanliness and proper functionality according to the operating instructions of the alarm system.

The cleaning intervals must be arranged such that the storage capacity of the separator and the sludge trap is not exceeded and the functionality is not interrupted. The separators must be drained at a level of separated light fluid volume corresponding with 80% of the storage capacity, and the sludge traps/volume if they are at half level of capacity as per following chart:

Designation	Sludge storage		Oil storage		
	Volume	Coating thickness	Volume	Coating thickness	
	[l/s]	[l]	[l]	max. [cm]	80 % [cm]
3-300	300	53,0	300	33,0	28,0
3-400T	400	66,5	500	56,5	44,5
3-600 6-600	600	86,5	300	33,0	26,0
6-1300T 10-1300T	1300	65,0	500	31,0	26,0
10-2000T 15-2000T	2000	80,8	660	34,1	28,4

3. Operation and maintenance according to EN 858-2

3.2.2. Semi-annual check

1. Cleaning of the sampling shaft.
2. Cleaning of the coalescence unit parts.
3. Drainage of the separator system, if necessary.

3.2.3. Maintenance by service company / waste management company

Please proceed as follows when draining the separator:

1. Extract the oil layer.
 - Extracted oil must only be temporarily stored in facilities approved for storing oil.
2. Extract the water phase/floating substances completely underneath by means of suction.
3. Sludge trap area must be purged with a high pressure cleaner and extracted again.
4. Refill the drainage bend in case no more water is left.
5. Refill the complete separator with clean water.

In general, it must be made sure that the float is floating freely and does not plug the outlet opening.

3.2.4. What to Do in the Event of a Fault

If the water is no longer able to flow freely through the separator system inlet

- a. Check the thickness of the oil layer.
- b. Check the proper function of the float.
- c. Notify the maintenance company

3. Operation and maintenance according to EN 858-2

Operating Manual

Operating year: _____

Monthly		JAN	FEB	MAR	APR	MAY	JUN	JUL	AUG	SEP	OCT	NOV	DEC
Layer thickness of the light fluid in the separator	[mm]												
Sludge level in sludge trap	[yes/no]												
Is the float free floating and does it close tightly?	[yes/no]												
Is the warning system functioning properly?	[yes/no]												
Have the coarse floating substances in the sludge trap and separator been removed?	[yes/no]												
Coalescence insert plugged and cleaned?	[yes/no]												
Any visual defects?	[yes/no]												
Are the covers IO?	[yes/no]												
Are inlet, outlet and connection lines unplugged?	[yes/no]												
Has sludge and / or light fluid been removed?	[yes/no]												

Semi annually		JAN	FEB	MAR	APR	MAY	JUN	JUL	AUG	SEP	OCT	NOV	DEC
Sludge removed from separator and separator cleaned?	[yes/no]												
Coalescence insert cleaned?	[yes/no]												
Sampling port cleaned?	[yes/no]												

4. Record of Commissioning:

4. Record of Commissioning:

4.1. Measures taken during installation

The watertightness test was carried out and recorded by a qualified person in accordance with the requirements from the relevant responsible authorities:

Date: _____

Stamp: _____

Signature: _____

Company responsible for the installation: _____

4.2. Measures taken during commissioning

1. The identification plate was attached to the shaft structure with dowels.

Carried out by: _____ date: _____

Signature _____
Company responsible for the
installation: _____

2. All tanks in the separator system were filled with fresh water.

Carried out by: _____ date: _____

Signature: _____

3. The float for automatic closure was inserted.

Inserted by: _____ date: _____

Signature: _____

3. The operating manual was handed over.

Inserted by: _____ date: _____

Signature Operator: _____